

vEX
ROBOTICS
COMPETITION
OVER UNDER

2023 - 2024
Game Manual
Version 4.0

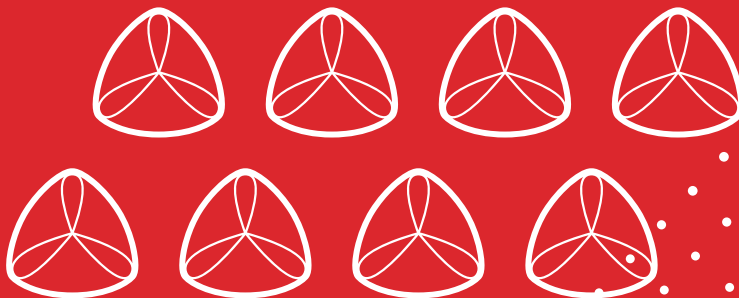

Table of Contents

Section 1

Introduction	1
--------------------	---

Section 2

The Game	6
General Definitions.....	8
Game-Specific Definitions	13
Scoring.....	21
Safety Rules	25
General Game Rules	25
Specific Game Rules.....	34

Section 3

The Robot	46
Inspection Rules.....	46

Section 4

The Tournament	60
Tournament Definitions.....	60
Tournament Rules.....	63

Section 5

VEX Worlds 2024 Update	74
------------------------------	----

Appendix A - Field Overview

Game Field Introduction.....	A1
Field Overview.....	A2
Game Objects & Field Bill of Materials	A3
Field Specifications Introduction.....	A4
Helpful Tips to Ensure Proper Goal Performance ..	A5
Accessibility Note - Marking Alliance Triballs	A5
Permitted Field Modifications.....	A21

Appendix B - Robot Skills

Robot Skills Challenge Description.....	B1
Robot Skills Challenge Definitions	B2
Robot Skills Challenge Rules	B3
Robot Skills Challenge Scoring	B4
Skills Stop Time	B5
Robot Skills Challenge Ranking at Events	B6
Robot Skills Challenge Ranking Globally	B7
League Events	B7

Appendix C - VEX U

Event Information	C1
Game, Robot, and Tournament Rules.....	C1
VEX U Definitions.....	C1
Rule Modifications: Field Setup	C2
Rule Modifications: Game.....	C3
Rule Modifications: Tournament	C4
Rule Modifications: Robot Skills Challenge.....	C6
Rule Modifications: Robot.....	C7
Team Composition	C13
Game, Robot, and Tournament Rules.....	D1
Rule Modifications: Field Setup	D1
Game Definitions.....	D1

Appendix D - VEX AI

Rule Modifications: Game.....	D3
Rule Modifications: Tournament	D4
Rule Modifications: Robot.....	D5

Changelog

Version 4.0 - April 2, 2024

- Added Section 5, containing important information for the 2024 VEX Robotics World Championship
- Added new grey boxes to various rules throughout the manual to note significant Q&A's that *Teams* should be aware of before the VEX Robotics World Championship
- Updated the definitions of *Offensive Zone* and *Elevation Tier* to clarify boundaries
- Added a new bullet point and note to <SC2> to clarify intent
- Updated <G8> to clarify intent
- Updated <SG2> to clarify intent
- Added a red box to <SG10> to clarify *Neutral Zone* interactions during the *Autonomous Period*
- Updated <R6> to include microSD cards for in-*Match* file storage
- Updated <R12a> to clarify intent
- Updated <R14c> to clarify that EXP Smart Motors (5.5W) are also included
- Updated <T7b> to note that the V5 white screen error is no longer a permitted cause for a replay
- Added a note to Appendix A to state that *Goals* will be secured to field risers at the VEX Robotics World Championship
- Minor typo / formatting fixes

Version 3.0 - January 30, 2024

- Updated the definition of *Goal* to provide clarity
- Removed the yellow *Elevation Bar Cap* from VRC and *Skills Matches*. This change does NOT apply to VEX U, or VAIRC
- Updated various figures throughout to remove the *Elevation Bar Cap*
- Updated the definitions of *Elevation Bar Cap* and *Elevated*
- Updated <SG6> with a new table and violation notes to clarify intent
- Updated <SG9> to clarify intent
- Updated <R18f> to clarify intent
- Updated <SG11> to reduce the Short *Barrier* protection time from 30 seconds to 15 seconds
- Updated the VEX U Field Setup rule modifications to specify that *Elevation Bar Caps* must be used

Version 2.2 - December 5, 2023

- Added a red box to the definition of *Holding* to clarify intent
- Updated Figure 16 to provide clarity
- Updated <SC7> to clarify intent in rewarding the *Autonomous Win Point*
- Updated <G7> to clarify clamping onto *Match Load Bars*
- Added a note to <G11> to clarify that *Robots* may be manually disabled during the *Autonomous Period*
- Updated <SG3> to clarify that *Triballs* may not be intentionally / repeatedly removed from the field
- Updated <SG6> to clarify intent, and provide links to official Q&A clarifications
- Added a new violation note and note to <SG7> to clarify that excess *Triballs* should be removed in a non-scored position
- Updated <SG11> to clarify intent, and explain the process of assigning an *Elevation Tier* if no other *Robots* are *Elevated*
- Updated <R7> to include SD Cards installed in the V5 Robot Brain
- Updated <R9> to clarify that license plates must be placed on opposing sides of the *Robot*
- Updated <T23> to clarify intent

- Updated Sheet 15 in Appendix A to show the correct field layout
- Updated <RSC4> to clarify that <SG8> does not apply for *Robot Skills Matches*
- Updated <VUR1> to include <VUR14>
- Updated <VUR4> to include C-Channel and U-Channel
- Removed Bearings from <VUR9>, and added them to a new rule, <VUR14> to clarify intent.
- Updated <VAIT2> to clarify intent
- Minor typo / formatting fixes

Version 2.1 - October 3, 2023

- Added a new definition of *Plowing*
- Updated the definition of *Possession* to clarify intent and explain relation to *Plowing*
- Updated <SC5> to clarify the criteria of scoring *Alliance Triballs*
- Updated <G1> to include a link to the Code of Conduct process
- Updated <G5> to clarify that *Robots* may not use external influences to satisfy starting size limits
- Added a red box to <SG5> allowing *Teams* an opportunity at the *Head Referee's* discretion to untangle themselves from the net if it occurs during the *Autonomous Period*
- Updated <SG6> with a new bullet point, image, and notes to clarify intent
- Updated <SG11> to clarify intent of non *Match Affecting Violations*
- Updated <R7b> to clarify that greasing V5 Smart Motor cartridges is prohibited
- Updated <T11> to clarify intent of repairing a broken net
- Updated Appendix A to include allowed field modifications
- Updated <VUG1> to clarify that *Teams* may adjust the starting position of *Alliance Triballs* per <SG1>
- Updated <VUG5> to clarify that *Alliances* may only use the *Match Load Zone* adjacent to the *Robot Starting Tiles* during the *Autonomous Period* of a *Head-to-Head Match*
- Updated <VUR3> to allow molding of non-metals
- Updated the tables in <VUR4> and <VUR5> to clarify intent
- Added Appendix D (VEX AI Robotics Competition)
- Minor typo / formatting fixes

Version 2.0 - August 1, 2023

- Updated <G8> to clarify the legality of items brought to the field by Drive Team Members
- Updated <R22a> and added a note to clarify pneumatic reservoir legality
- Updated <T1e> to clarify that a Head Referee may only watch one Match at a time
- Updated <T11> to address using PVC to replace a damaged section of a Goal
- Updated figure 41 to fix the position of misaligned Triballs
- Minor typo / formatting fixes

Version 1.1 - July 11, 2023

- Added VEX U Robot Rules

Version 1.0 - June 27, 2023

- Updated point 1b in the definition of *Elevated* to state that a *Robot* must be contacting any portion of the *Barrier* that is on their *Alliance's* side of the Neutral Zone
- Added point 4 to the definition of *Elevated* to state that a *Robot* may not be contacting an *Alliance* partner *Robot* that is not considered *Elevated*
- Added a note to <SC7> to clarify intent
- Added a note to <SG1> and <RSC2e> to clarify that the *Triballs* beginning in *Match Load Zones* may be repositioned by *Teams*. The note in <G9> was also updated to reflect this change
- Revised <SG3> to state that any *Triballs* that leave the field will be returned to the nearest *Match Load Zone*
- Added a *Violation* note to <SG9> to clarify intent
- Added <SG11d>, stating that *Robots* may not contact the Short *Barriers* adjacent to the opposing *Alliance's* *Elevation Bars* during the last thirty (30) seconds of the *Match*
- Updated <T9> to provide clarity regarding when *Time Outs* may be used
- Updated <T10> to provide a *Goal* height tolerance, and to provide further clarity
- Added a *Violation* note to <RSC1> to clarify intent
- Added Appendix C for VEX U
- Minor typo / formatting fixes

Version 0.2 - June 13, 2023

- Updated the definition of *Elevation Tier* to clarify that *Robots* must be “fully above the white line” of the *Height Guide* to receive credit for that *Elevation Tier*
- Added a note to <SC3>, clarifying that a *Triball* Scored in a *Goal* is not also considered Scored in that *Goal's* *Offensive Zone*
- Revised the note in <SG5> to clarify that the net cannot be lifted to score / de-score
- Updated <T5> to include *Autonomous Win Points*
- Updated <T8> to clarify that a *Team* that receives a *Disqualification* in a *Qualification Match* also receives a score of (0) for the *Match*
- Added an REC Library article link to <R7> to provide clarity
- Updated Robot Skills Challenge Ranking 9a to Number of *Triballs* Scored in *Goals*
- Minor typo / formatting fixes

Version 0.1 - April 29, 2023

- Initial Release

Quick Reference Guide

Scoring Rules (Pages 21-24)

<SC1>	All scoring statuses are evaluated immediately after the <i>Match</i> ends
<SC2>	Scoring of the <i>Autonomous Bonus</i> is immediately after the <i>Autonomous Period</i>
<SC3>	Scored in a <i>Goal</i> criteria
<SC4>	Scored in an <i>Offensive Zone</i> criteria
<SC5>	<i>Alliance Triballs</i>
<SC6>	<i>Elevation Tier</i> points
<SC7>	<i>Autonomous Win Point</i>

Safety Rules (Page 25)

<S1>	Be safe out there
<S2>	<i>Students</i> must be accompanied by an <i>Adult</i> .
<S3>	Stay inside the <i>Field</i>
<S4>	Wear safety glasses

General Game Rules (Pages 25-33)

<G1>	Treat everyone with respect
<G2>	VRC is a <i>Student</i> -centered program
<G3>	Use common sense
<G4>	The <i>Robot</i> must represent the skill level of the <i>Team</i>
<G5>	<i>Robots</i> begin the <i>Match</i> in the starting volume
<G6>	Keep your <i>Robots</i> together
<G7>	Don't clamp your <i>Robot</i> to the <i>Field</i>
<G8>	Only <i>Drive Team Members</i> , and only in the <i>Alliance Station</i>
<G9>	Hands out of the <i>Field</i>
<G10>	Controllers must stay connected to the <i>Field</i>
<G11>	Autonomous means "no humans"
<G12>	All rules still apply in the <i>Autonomous Period</i>
<G13>	Don't destroy other <i>Robots</i> . But, be prepared to encounter defense
<G14>	Offensive <i>Robots</i> get the "benefit of the doubt"
<G15>	You can't force an opponent into a penalty
<G16>	No <i>Holding</i> for more than a 5-count
<G17>	Use <i>Triballs</i> to play the game

Specific Game Rules (Pages 34-45)

<SG1>	Starting a <i>Match</i>
<SG2>	Horizontal expansion is limited
<SG3>	Keep <i>Triballs</i> in the Field
<SG4>	Each <i>Robot</i> gets one <i>Alliance Triball</i> as a <i>Preload</i>
<SG5>	Stay away from nets on the <i>Goals</i>
<SG6>	Match Load <i>Triballs</i> may be safely introduced during the <i>Match</i> under certain conditions
<SG7>	<i>Possession</i> is limited to one (1) <i>Triball</i>
<SG8>	Stay out of your opponent's <i>Goal</i> unless they are <i>Double-Zoned</i>
<SG9>	Stay in your starting zone during the <i>Autonomous Period</i>
<SG10>	Enter the <i>Neutral Zone</i> during the <i>Autonomous Period</i> at your own risk
<SG11>	<i>Elevated Robots</i> are protected

Robot Rules (Pages 46-59)

<R1>	One <i>Robot</i> per <i>Team</i>
<R2>	<i>Robots</i> must represent the <i>Team's</i> skill level
<R3>	<i>Robots</i> must pass inspection
<R4>	<i>Robots</i> must fit within an 18" x 18" x 18" volume
<R5>	<i>Robots</i> must be safe
<R6>	<i>Robots</i> are built from the VEX V5 system
<R7>	Certain non-VEX components are allowed
<R8>	Decorations are allowed
<R9>	Officially registered <i>Team</i> numbers must be displayed on <i>Robot License Plates</i>
<R10>	Let go of <i>Triballs</i> after the <i>Match</i>
<R11>	<i>Robots</i> have one microcontroller
<R12>	Motors are limited
<R13>	Electrical power comes from VEX batteries only
<R14>	No modifications to electronic components are allowed
<R15>	Most modifications to non-electrical components are allowed
<R16>	<i>Robots</i> use VEXnet
<R17>	Give the radio some space
<R18>	A limited amount of custom plastic is allowed
<R19>	A limited amount of tape is allowed
<R20>	Certain non-VEX fasteners are allowed
<R21>	New VEX parts are legal
<R22>	Pneumatics are limited
<R23>	One or two Controllers per <i>Robot</i>
<R24>	Custom V5 Smart Cables are allowed
<R25>	Keep the power button accessible
<R26>	Use a "Competition Template" for programming
<R27>	There is a difference between accidentally and willfully violating a <i>Robot</i> rule

Tournament Rules (Pages 63-73)

<T1>	<i>Head Referees</i> have final authority on all gameplay ruling decisions
<T2>	<i>Head Referees</i> must be qualified
<T3>	The Drive Team is permitted to immediately appeal a <i>Head Referee's</i> ruling
<T4>	<i>Event Partners</i> have final authority regarding all non-gameplay decisions
<T5>	A <i>Team's Robot</i> and/or <i>Drive Team Member</i> should attend every <i>Match</i>
<T6>	<i>Robots</i> at the field must be ready to play
<T7>	<i>Match</i> replays are allowed, but rare
<T8>	<i>Disqualifications</i>
<T9>	Each elimination <i>Alliance</i> gets one <i>Time Out</i>
<T10>	Be prepared for minor Field variance
<T11>	Fields may be repaired at the <i>Event Partner's</i> discretion
<T12>	The red <i>Alliance</i> places last
<T13>	<i>Qualification Matches</i> follow the <i>Match Schedule</i>
<T14>	Each <i>Team</i> will have at least six <i>Qualification Matches</i>
<T15>	<i>Qualification Matches</i> contribute to a <i>Team's</i> ranking for <i>Alliance Selection</i>
<T16>	<i>Qualification Match</i> tiebreakers
<T17>	Send a <i>Student</i> representative to <i>Alliance Selection</i>
<T18>	Each <i>Team</i> may only be invited once to join an <i>Alliance</i>
<T19>	<i>Elimination Matches</i> follow the <i>Elimination Bracket</i>
<T20>	<i>Elimination Matches</i> are a blend of "Best of 1" and "Best of 3"
<T21>	The number of <i>Alliances</i> is determined by the size of the tournament
<T22>	Fields at an event must be consistent with each other
<T23>	There are three types of field control that may be used
<T24>	There are two types of field perimeter that may be used

Robot Skills Challenge Rules (Pages B3-B4)

<RSC1>	All rules from "The Game" section of the manual apply to the Robot Skills Challenge
<RSC2>	<i>Robots</i> may start the <i>Robot Skills Match</i> in any legal starting location
<RSC3>	<i>Teams</i> may utilize the forty-four (44) Match Load <i>Triballs</i>
<RSC4>	<i>Teams</i> play as if they are on the red <i>Alliance</i>
<RSC5>	Elevation points are awarded based on the <i>Elevation Tier</i>
<RSC6>	Skills Challenge fields do not require the same modifications as the Head-to-Head Fields
<RSC7>	<i>Triballs</i> which come to rest on top of the red <i>Goal</i> may not be retrieved

VEX U Game Rules (Pages C3-C4)

<VUG1>	Different <i>Starting Tiles</i>
<VUG2>	Different <i>Preloads</i>
<VUG3>	Different Autonomous Zones
<VUG4>	Different Match Load introductions
<VUG5>	Different Match Load availability
<VUG6>	Different <i>Autonomous Win Point</i>

VEX U Tournament Rules (Pages C4-C5)

<VUT1>	VEX U <i>Matches</i> will be played 1- <i>Team</i> vs. 1- <i>Team</i>
<VUT2>	<i>Qualification Matches</i> will be conducted in the 1v1 format
<VUT3>	<i>Elimination Matches</i> will be conducted without an <i>Alliance Selection</i>
<VUT4>	The <i>Autonomous Period</i> at the beginning of each Head-to-Head <i>Match</i> will be 45 seconds
<VUT5>	The <i>Driver Controlled Period</i> is shortened to 75 seconds
<VUT6>	Each <i>Robot</i> is allowed up to three (3) <i>Drive Team Members</i> in the <i>Alliance Station</i>
<VUT7>	VEX U <i>Student</i> eligibility

VEX U Robot Skills Rules (Page C6)

<VURS1>	One <i>Robot</i> must start the <i>Robot Skills Match</i> in each set of <i>Starting Tiles</i>
<VURS2>	The field is set up the same as a standard <i>Robot Skills Match</i>
<VURS3>	The <i>Elevation Tier</i> scoring listed in rule <RSC5> is used for both <i>Robots</i> .

VEX U Robot Rules (Pages C7-C13)

<VUR1>	<i>Teams</i> may use two (2) <i>Robots</i> in each <i>Match</i> .
<VUR2>	<i>Teams</i> may use any official VEX Robotics products
<VUR3>	<i>Fabricated Parts</i>
<VUR4>	<i>Fabricated Parts</i> must be made from legal <i>Raw Stock</i>
<VUR5>	<i>Raw Stock</i>
<VUR6>	<i>Fabricated Parts</i> may not be made from <i>Raw Stock</i> which poses a safety or damage risk
<VUR7>	<i>Fabricated Parts</i> must be made by <i>Team</i> members
<VUR8>	Springs
<VUR9>	Fasteners
<VUR10>	One (1) V5 Robot Brain and up to two (2) V5 Robot Radios
<VUR11>	No motor restrictions
<VUR12>	No sensor and <i>Additional Electronics</i> restrictions
<VUR13>	Unlimited amount of the following commercially available pneumatic components
<VUR14>	<i>Teams</i> may use commercially available bearings on their <i>Robot</i>

VEX AI Game Rules (Pages D3-D4)

<VAIG1>	All <VUGx>, <SCx>, and <Sx> rules apply as written
<VAIG2>	<i>Drive Team Members</i> are not permitted to interact with their <i>Robots</i> during Autonomous
<VAIG3>	VAIRC <i>Teams</i> are responsible for the actions of their <i>Robots</i> throughout the <i>Match</i>
<VAIG4>	<i>Robots</i> are only permitted to "break the plane" of an opponent's <i>Goal</i> if they are <i>Double-Cornered</i>

VEX AI Tournament Rules (Pages D4-D5)

<VAIT1>	The following VEX U rules apply
<VAIT2>	VEX AI Robotics Competition <i>Student</i> eligibility
<VAIT3>	<i>Students</i> may only participate on one (1) VAIRC <i>Team</i> in a given season

VEX AI Robot Rules (Page D5)

<VAIR1>	All <VURx> rules apply as written
<VAIR2>	Any components used for AI vision processing are considered <i>Additional Electronics</i>
<VAIR3>	The <i>Robot(s)</i> built by a <i>Base Team</i> may be used by their <i>Crossover Team</i> for VAIRC <i>Matches</i>

Section 1

Introduction

Overview

This section provides an introduction to the VEX Robotics Competition (VRC) and VRC Over Under.

The VEX Robotics Competition

Our world faces a serious problem. It's a problem that, without explicit and intentional action, will eventually stagnate global progress and lead to a workforce that is unmotivated and ill-equipped to solve its future problems. As the world grows more technologically complex, the challenges we face every day will continue to escalate along with it. A cell phone has more failure modes than a landline. The internals of an electric vehicle are more difficult to comprehend than a V8 combustion engine. Unmanned drone legislation is more nuanced than defining a maximum speed limit.

Dubbed "the STEM problem," the situation is equally simple to understand, yet difficult to solve. In many cases, the traditional methods of teaching science, technology, engineering, and math (STEM) will not be enough to adequately prepare students for this complex world. This is often coupled with the unfortunate reality that by the time they reach an age capable of grasping these critical topics, students may have already determined that they are "not cool" or "boring." Without the skills or passion necessary to approach these problems in an educated manner, you cannot possibly expect to be productive in making forward progress or even sustaining the status quo.

The VEX Robotics Competition exists to solve this problem. Through its uniquely engaging combination of teamwork, problem solving, and scientific discovery, the study of competitive robotics encompasses aspects of STEM. You're not building VEX robots because your future job will involve tightening shaft collars on a metal bar—you're executing an engineering design and problem-solving process that resembles the same mindset used by rocket scientists, brain surgeons, and inventors around the world. VEX Robotics Competition Over Under is not just a game that we invented because it is fun to play—it is a vehicle for teaching (and testing) teamwork and perseverance in the face of hardship, and provides a methodology to approach and solve new challenges with confidence.

Contained in this manual are the rules that shape VRC Over Under. These rules are designed to simulate the constraints that will outline any real-world project. They are intended to promote creativity without punishing innovation. They are balanced to promote fair play while encouraging competition.

We encourage you to keep in mind that a VEX Robotics Competition game is more than just a set of game objectives worth varying amounts of points. It is an opportunity to hone the lifelong skills that will characterize the problem-solving leaders of tomorrow.

Good luck, and we'll see you on the playing field!

Sincerely,

The VEX Robotics Game Design Committee, composed of members from the Robotics Education & Competition Foundation, DWAB Technology, and VEX Robotics

VEX Robotics Competition Over Under: A Primer

VEX Robotics Competition Over Under is played on a 12'x12' square field, set up as illustrated in the figures throughout.

In Head-to-Head Matches, two (2) *Alliances*—one (1) "red" and one (1) "blue"—composed of two (2) *Teams* each, compete in *Matches* consisting of a fifteen (15) second *Autonomous Period* followed by a one minute and forty-five second (1:45) *Driver Controlled Period*.

The object of the game is to attain a higher score than the opposing *Alliance* by Scoring *Triballs* in *Goals* and by *Elevating* at the end of the *Match*.

An *Autonomous Win Point* is awarded to any *Alliance* that completes three (3) assigned tasks by the end of the *Autonomous Period*.

An *Autonomous Bonus* is awarded to the *Alliance* that has the most points at the end of the *Autonomous Period*.

Teams may also compete in *Robot Skills Matches*, where one (1) *Robot* tries to score as many points as possible. See Appendix B for more information.

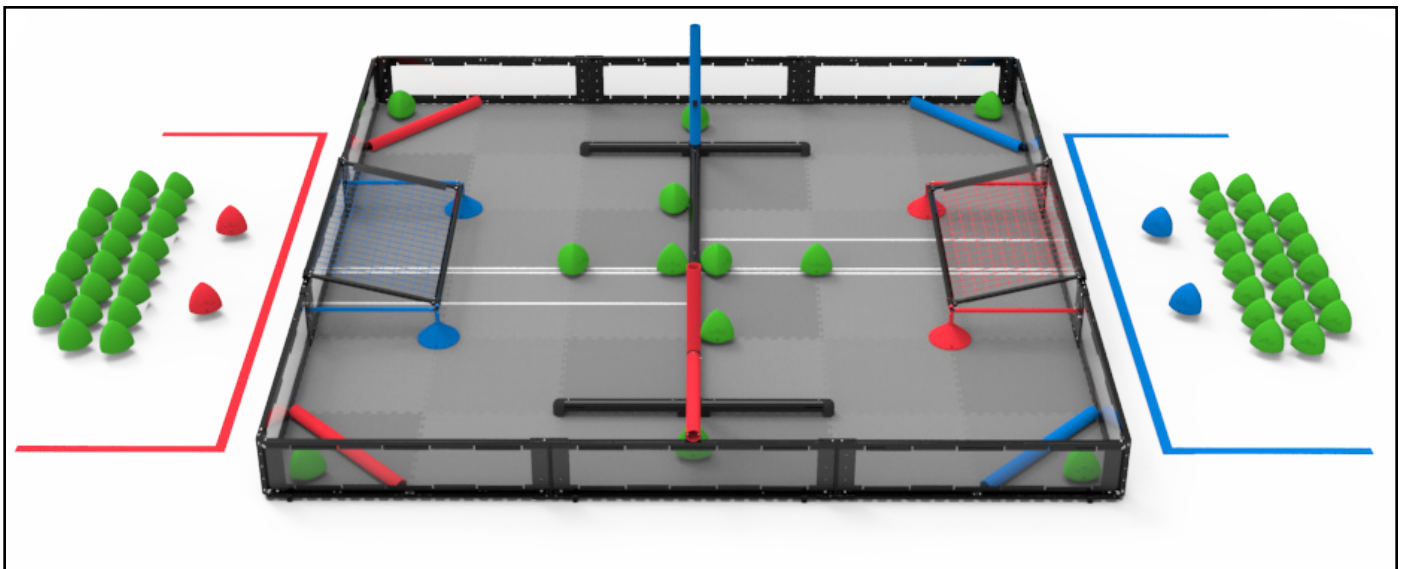

About the Game Manual - A Note from the GDC

This Game Manual and its appendices contain everything there is to know about this season's game, VRC Over Under. It is intended to be a resource for all *Teams*, *Head Referees*, *Event Partners*, and other members of the VRC community.

The rules contained in the following pages can be thought of as "constraints" that define this game, just as engineers begin any design project by defining their constraints. At the beginning of a season, "constraints" are all we have. We don't know what the winning *Robot*, best strategy, or most-frequently-violated rule will be any more than you do. Isn't that exciting?

When exploring a new game, please approach this Game Manual with that mentality of looking at rules as "constraints." The Game Manual and its appendices contain the full and complete list of constraints that are available for a competitor to strategize, design, and build their *Robots*.

Obviously, all *Teams* must adhere to these rules, and any stated intents of these rules. However, beyond that, there is no "right" way to play. There are no hidden restrictions, assumptions, or intended interpretations beyond what is written here. So, it is up to you, the competitor, to find the path through these constraints that best suits your team's goals and ambitions.

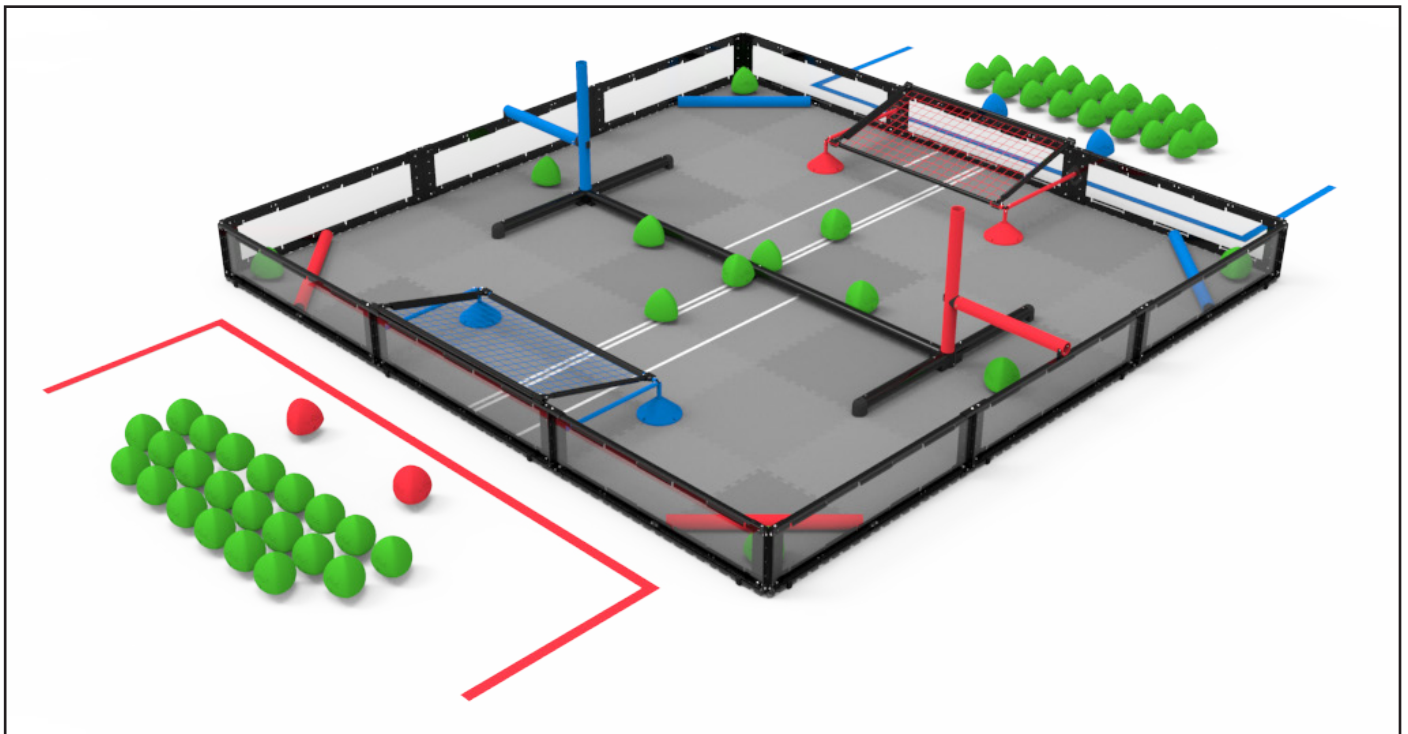

Updates

This manual will have a series of “major” and “minor” updates over the course of the season. Each version is official and must be used in official VRC events until the release of the next version, upon which the previous version becomes void.

The latest version of the Game Manual can always be found at <https://link.vex.com/docs/23-24/vrc-over-under/GameManual>.

Known major release dates are as follows:

April 29, 2023	Version 0.1	Initial game release
May 16, 2023	N/A	Official Q&A system opens
June 13, 2023	Version 0.2	Minor typographical errors or formatting issues found in the initial release. There will be very few rule changes, if any.
June 27, 2023	Version 1.0	May include critical gameplay or rule changes inspired by input from the official Q&A system and the VEX community.
August 1, 2023	Version 2.0	May include gameplay or rule changes inspired by early-season events.
October 3, 2023	Version 2.1	Clarification update only
December 5, 2023	Version 2.2	Clarification update only
January 30, 2024	Version 3.0	May include gameplay or rule changes inspired by mid-season events.
April 2, 2024	Version 4.0	May include critical gameplay or rule clarifications pertaining specifically to the VEX Robotics World Championship

In addition to these known major updates, there may also be unscheduled updates released throughout the season if deemed critical by the GDC. **Any unscheduled updates will always be released on a Tuesday, no later than 5:00 PM CST (11:00 PM GMT).** These updates will be announced via the VEX Forum, automatically pushed to the VRC Hub app, and shared via VEX Robotics / REC Foundation social media & email marketing channels.

Game Manual updates are effective immediately upon release; it is every *Team’s* responsibility to be familiar with all rules and updates. There are no “grace periods” if an update prohibits a previously legal part, mechanism, or strategy.

Note: REC Foundation Event Support Managers will contact Event Partners involved with multi-week league events that “cross over” an unscheduled update. If a rule change impacts their event (such as a Robot which previously passed inspection no longer being legal), these cases will be reviewed individually depending on the context of the event and the rule that has changed. This is the only possible “grace period” exception.

The Q&A System

When first reviewing a new robotics game, it is natural to have questions about situations which may not be immediately clear. Navigating the Game Manual and seeking out answers to these questions is an important part of learning a new game. In many cases, the answer may just be in a different place than you first thought—or, if there is no rule explicitly prohibiting something, then that usually means it is legal!

However, if a *Team* is still unable to find an answer to their question after closely reviewing the relevant rules, then every *Team* has the opportunity to ask for official rules interpretations in the VEX Robotics Question & Answer System. These questions may be posted by a *Team's Adult* representative via the RobotEvents account that is associated with that *Team*.

All responses in this Q&A system should be treated as official rulings from the VEX Robotics *Game Design Committee*, and they represent the correct and official interpretation of the VEX Robotics Competition Rules. The Q&A system is the only source besides the Game Manual for official rulings and clarifications.

The VEX Robotics Competition Question & Answer System can be found at <https://www.robotevents.com/VRC/2023-2024/QA>.

Before posting on the Q&A system, be sure to review the Q&A Usage Guidelines, which can be found at <https://www.robotevents.com/VRC/2023-2024/QA/guidelines>.

1. Read and search the manual before posting.
2. Read and search existing Q&As before posting.
3. Quote the applicable rule from the latest version of the manual in your question.
4. Make a separate post for each question.
5. Use specific and appropriate question titles.
6. Questions will (mostly) be answered in the order they were received.
7. This system is the only source for official rules clarifications.

If there are any conflicts between the Game Manual and other supplemental materials (e.g., Referee Certification courses, the VRC Hub app, etc.), the most current version of the Game Manual takes precedence.

Similarly, it can never be assumed that definitions, rules, or other materials from previous seasons apply to the current game. Q&A responses from previous seasons are not considered official rulings for the current game. Any relevant clarifications that are needed should always be re-asked in the current season's Q&A.

Section 2

The Game

Field Overview

The VEX Robotics Competition Over Under field consists of the following:

- Sixty (60) *Triballs*
 - Four (4) *Alliance Triballs*, two (2) per *Alliance*, that can be used as *Preloads*
 - Forty-four (44) that are used as Match Loads, twenty-two (22) per *Alliance*
 - Twelve (12) that begin on the field
- Two (2) sets of *Elevation Bars*, one (1) per *Alliance*
- Two (2) *Goals*, one (1) per *Alliance*
- Four (4) *Match Load Bars / Match Load Zones*, two (2) per *Alliance*

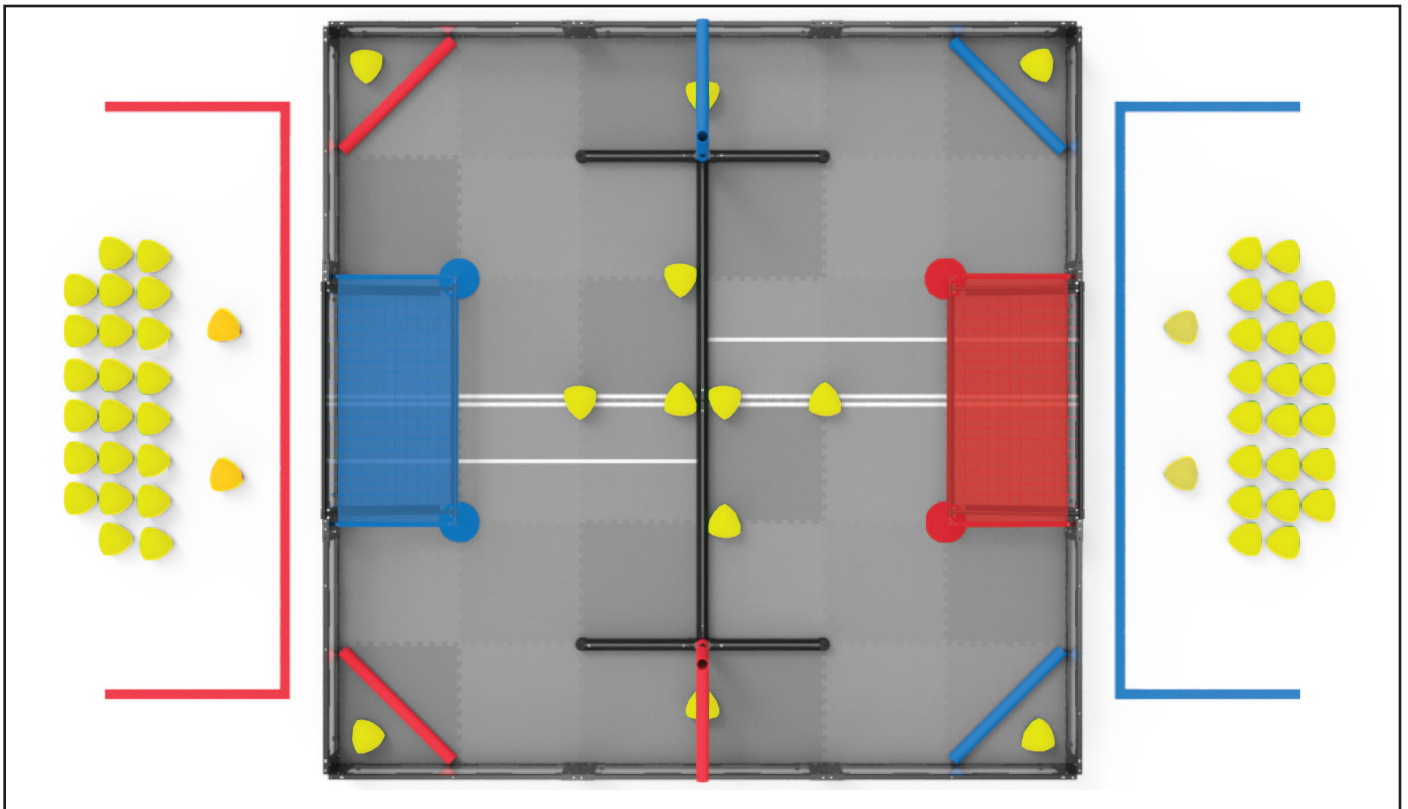

Figure 1: Top view of the field in its starting configuration, with highlighted Triballs (yellow), Red Alliance Goal (red), and Blue Alliance Goal (blue).

Note: The illustrations in this section of the Game Manual are intended to provide a general visual understanding of the game. Teams should refer to official field specifications, found in Appendix A, for exact field dimensions, a full field bill of materials, and exact details of field construction.

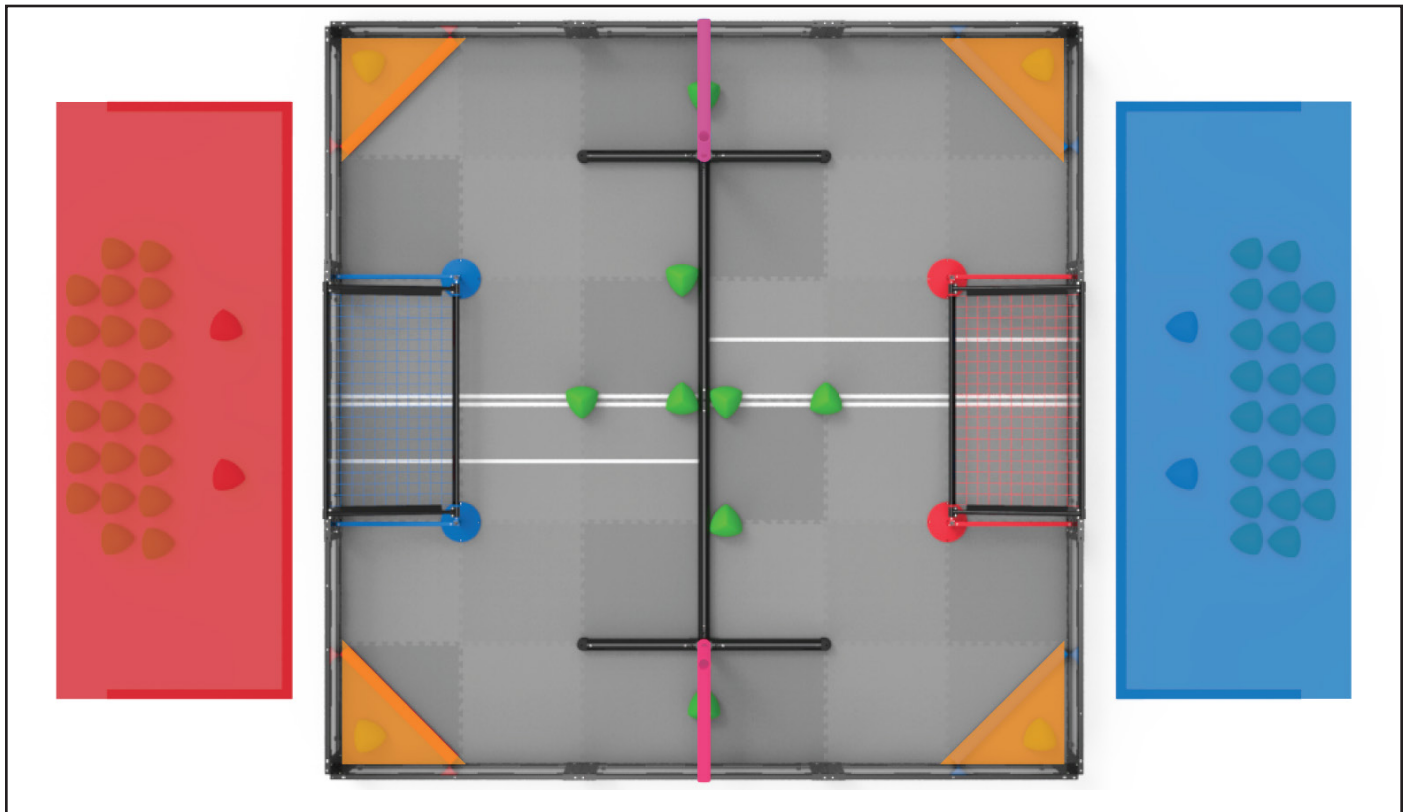

Figure 2: Top view of the field with highlighted Elevation Bars (pink), Match Load Zones (orange), Red Alliance Station (red) and Blue Alliance Station (blue).

General Definitions

Adult – Anyone who is not a *Student* or another defined term (e.g., *Head Referee*).

Alliance – A pre-assigned grouping of two (2) *Teams* that are paired together during a given *Match*.

Alliance Station – The designated regions where the *Drive Team Members* must remain for the duration of the *Match*.

Autonomous Bonus – A point bonus awarded to the *Alliance* that has earned the most points at the end of the *Autonomous Period*. See <SC2> for more information.

Autonomous Win Point - An additional *Win Point* awarded to any *Alliance* that has completed a defined set of tasks at the end of the *Autonomous Period* of a *Qualification Match*. See <SC7> for more information.

Disablement – A penalty applied to a *Team* for a rule *Violation*. A *Team* that is Disabled is not allowed to operate their *Robot* for the remainder of the *Match*, and the *Drive Team Member(s)* will be asked to place their controller(s) on the ground.

Disqualification – A penalty applied to a *Team* for a rule *Violation*. A *Team* that receives a *Disqualification* in a *Qualification Match* receives zero (0) *Win Points*, (0) *Autonomous Win Points*, (0) *Autonomous Points*, and (0) *Strength of Schedule Points*. When a *Team* is Disqualified in an *Elimination Match*, the entire *Alliance* is Disqualified and they receive a loss for the *Match*. At a *Head Referee's* discretion, repeated *Violations* and/or *Disqualifications* for a single *Team* may lead to its *Disqualification* for the entire tournament (see <T8>). A *Team* that receives a *Disqualification* in a *Driving Skills Match* or *Autonomous Coding Skills Match* receives a score of zero (0) for that *Robot Skills Match*.

Drive Team Member(s) – A *Student* who stands in the *Alliance Station* during a *Match*. Adults are not allowed to be *Drive Team Members*. See rules <G8>, <G9>, and <G10>.

Entanglement – A *Robot* status. A *Robot* is Entangled if it has grabbed, hooked, or attached to an opposing *Robot* or a *Field Element*. See rules <G13> and <SG5>.

Field Element – The foam field tiles, field perimeter, white tape, *Elevation Bars*, *Match Load Bars*, *Goals*, and all supporting structures or accessories (such as *Alliance Station* posts, field monitors, etc.).

Game Design Committee (GDC) - The creators of VRC Over Under, and authors of this Game Manual.

Holding - A *Robot* status (see rule <G16>). A *Robot* is considered to be *Holding* if it meets any of the following criteria during a *Match*:

- **Trapping** - Limiting the movement of an opponent *Robot* to a small or confined area of the field, approximately the size of one foam field tile or less, without an avenue for escape. Note that if a *Robot* is not attempting to escape, it is not considered Trapped.
- **Pinning** - Preventing the movement of an opponent *Robot* through contact with the Field Perimeter, a Field or Game Element, or another *Robot*.
- **Lifting** - Controlling an opponent's movements by raising or tilting the opponent's *Robot* off of the foam tiles.

If the *Head Referee* determines that the opponent *Robot* is not attempting to move or escape, then it is not considered *Pinned* or *Trapped*. This commonly occurs when receiving Match Loads, or if the *Robot* has malfunctioned and lost the ability to move.

This criteria is not required for *Lifting*; the *Holding* status begins as soon as the opponent becomes *Lifted*.

Match – A set time period, consisting of *Autonomous* and/or *Driver Controlled Periods*, during which *Teams* play a defined version of Over Under to earn points. See Section 4.

- **Autonomous Period** – A time period during which *Robots* operate and react only to sensor inputs and commands pre-programmed by the *Students* into the *Robot* control system.
- **Driver Controlled Period** – A time period during which *Drive Team Members* operate their *Robot* via remote control.

Match Type	Participants	Pertinent Rules	Autonomous Period (m:ss)	Driver Controlled Period (m:ss)
Head-to-Head	Two <i>Alliances</i> (red/blue), each composed of two <i>Teams</i> , with one <i>Robot</i> each	Scoring ("SC"), Game ("G") and Specific Game ("SG") sections	0:15	1:45
Driving Skills Match	One <i>Team</i> , with one <i>Robot</i>	Appendix B	None	1:00
Autonomous Coding Skills Match	One <i>Team</i> , with one <i>Robot</i>	Appendix B	1:00	None

VEX U	Two <i>Teams</i> (red/blue), with two <i>Robots</i> each	Appendix C	0:45	1:15
VEX AI	Two <i>Teams</i> , (red/blue), with two <i>Robots</i> each, utilizing the VEX GPS and VEX AI Camera	Appendix D	0:15	1:45

Note: The time periods in VAIRC are referred to as the Isolation Period and the Interaction Period.

Robot – A machine that has passed inspection, designed to execute one or more tasks autonomously and/or by remote control from a *Drive Team Member*.

Student – A person is considered a *Student* if they meet both of the following criteria:

1. Anyone who is earning or has earned credit toward a high school diploma, certificate, or other equivalent during the six (6) months preceding the VEX Robotics World Championship. Courses earning credits leading up to high school would satisfy this requirement.
2. Anyone born after May 1, 2004 (i.e., who will be 19 or younger at VEX Worlds 2024). Eligibility may also be granted based on a disability that has delayed education by at least one year.
 - **Middle School Student** – A *Student* born after May 1, 2008 (i.e., who will be 15 or younger at VEX Worlds 2024). A *Middle School Student* may “play up” and compete as a *High School Student*.
 - **High School Student** – Any eligible *Student* that is not a *Middle School Student*.

Team – One or more *Students* make up a *Team*.

- A *Team* is classified as a *Middle School Team* if all members are *Middle School Students*.
- A *Team* is classified as a *High School Team* if any of its members are *High School Students*, or if the *Team* is made up of *Middle School Students* who declare themselves “playing up” as *High School Students* by registering their *Team* as a *High School Team*.
- Once a *Team* has competed in an event as a *High School Team*, that *Team* may not change back to a *Middle School Team* for the remainder of the season. *Teams* may be associated with schools, community/youth organizations, or groups of neighborhood *Students*.

In the context of this Game Manual, *Teams* contain three types of *Student* roles related to *Robot* build, design, and programming. See <G2> and <G4> for more information. *Adults* may not fulfill any of these roles.

- **Builder** – The *Student(s)* on the *Team* who assemble(s) the *Robot*. *Adults* are permitted to teach the *Builder(s)* how to use concepts or tools associated with *Robot* construction, but may never work on the *Robot* without the *Builder(s)* present and actively participating.

- **Designer** – The *Student(s)* on the *Team* who design(s) the *Robot*. *Adults* are permitted to teach the *Designer(s)* how to use concepts or tools associated with design, but may never work on the design of the *Robot* without the *Designer(s)* present and actively participating.
- **Programmer** – The *Student(s)* on the *Team* who write(s) the computer code that is downloaded onto the *Robot*. *Adults* are permitted to teach the *Programmer(s)* how to use concepts or tools associated with programming, but may never work on the code that goes on the *Robot* without the *Programmer(s)* present and actively participating.

Violation – The act of breaking a rule in the Game Manual.

- **Minor Violation** – A *Violation* which does not result in a *Disqualification*.
 - Accidental, momentary, or otherwise non *Match Affecting Violations* are usually *Minor Violations*.
 - *Minor Violations* usually result in a verbal warning from the *Head Referee* during the *Match*, which should serve to inform the *Team* that a rule is being *Violated* before it escalates to a *Major Violation*.
- **Major Violation** – A *Violation* which results in a *Disqualification*.
 - Unless otherwise noted in a rule, all *Match Affecting Violations* are *Major Violations*.
 - If noted in the rule, egregious or intentional *Violations* may also be *Major Violations*.
 - Multiple *Minor Violations* within a *Match* or tournament may escalate to a *Major Violation* at the *Head Referee's* discretion.
- **Match Affecting** – A *Violation* which changes the winning and losing *Alliance* in the *Match*.
 - Multiple *Violations* within a *Match* can cumulatively become *Match Affecting*.
 - When evaluating if a *Violation* was *Match Affecting*, *Head Referees* will focus primarily on any *Robot* actions that were directly related to the *Violation*.
 - Determining whether a *Violation* was *Match Affecting* can only be done once the *Match* is complete and the scores have been calculated.

Some rules include *Violation Notes* in *red italicized text* to denote special circumstances or provide additional clarifications. If no *Violation Notes* are found in a given rule, then it should be assumed that the above “default” definitions apply.

To determine whether a *Violation* may have been *Match Affecting*, check whether the *Team* who committed the *Violation* won or lost the *Match*. If they did not win the *Match*, then the *Violation* could not have been *Match Affecting*, and it was very likely a *Minor Violation*.

See the flowchart in Figure 3 for more information.

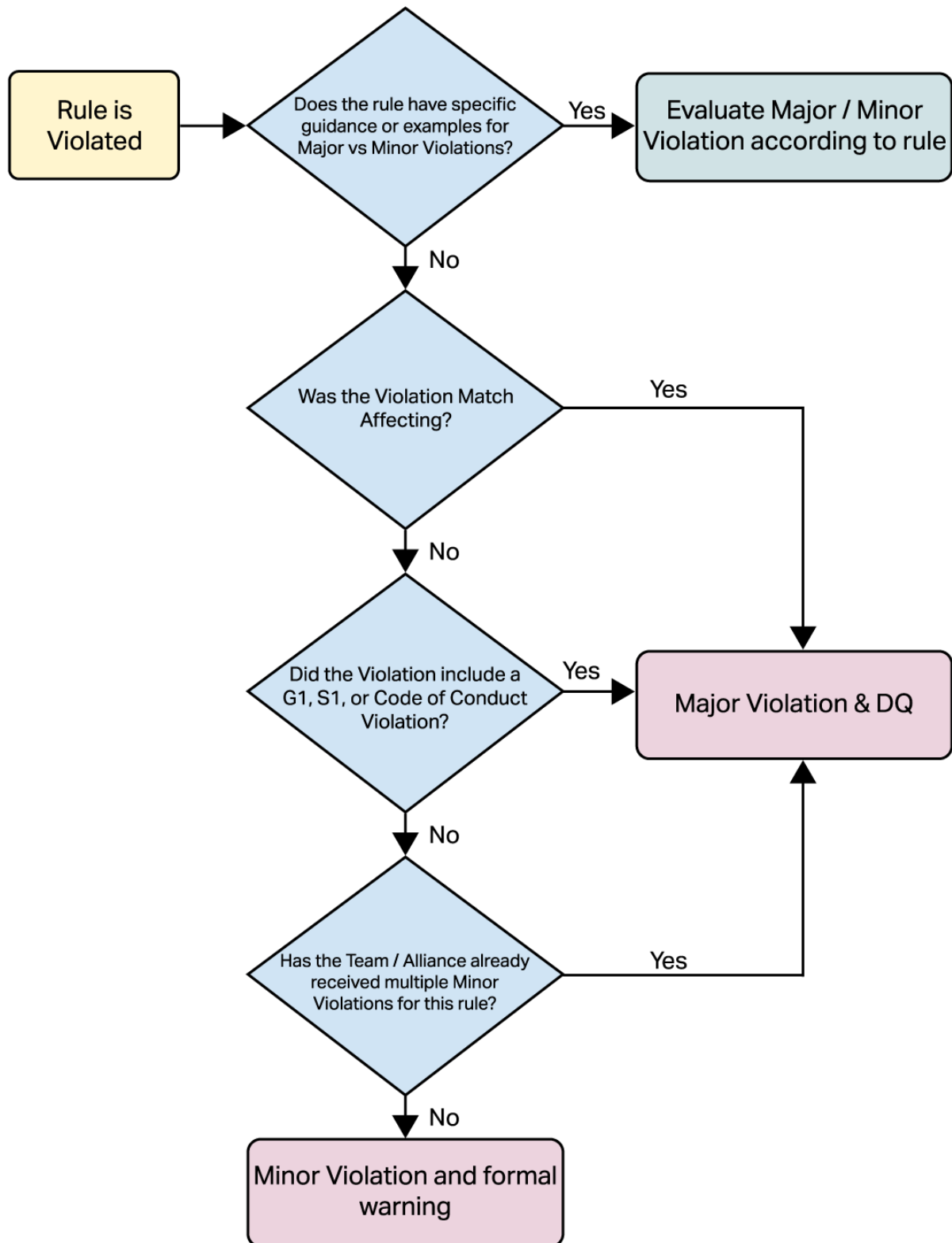

Figure 3: The process for determining whether or not an infraction should result in a Major Violation or Minor Violation.

Game-Specific Definitions

Alliance Triball – One of four *Triballs*, two per *Alliance*, that are *Alliance*-colored instead of green. *Alliance Triballs* may be used as *Preloads* or *Match Loads*.

Barrier – The black structure, made up of 2" Schedule 40 PVC pipe (with a 2.375" outer diameter) PVC pipe and associated connectors/hardware, that sits in the middle of the field. For some rules, the *Barrier* is divided into one *Long Barrier* and two *Short Barriers*, but it is usually referred to collectively as just "the *Barrier*."

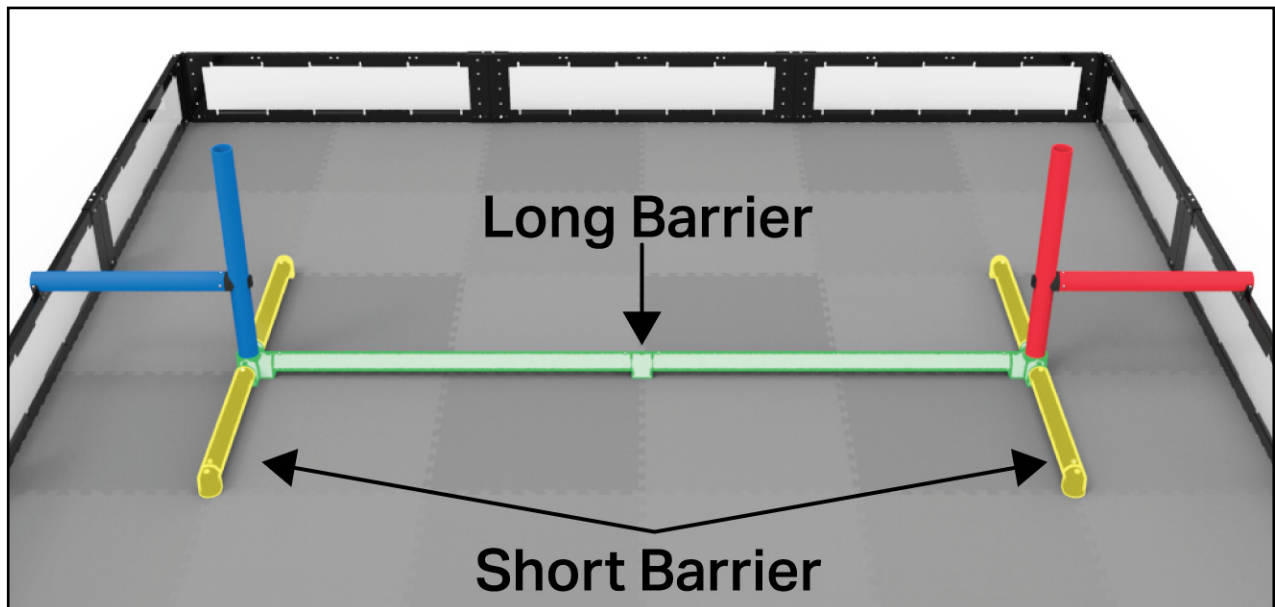

Figure 4: A view of the field, with the Short Barriers (yellow) and Long Barrier (green) highlighted.

Double-Zone – An *Alliance* status. An *Alliance* meets the definition of being "Double-Zoned" if both *Robots* from the *Alliance* are in the same *Offensive Zone*. To be considered "in the Zone" for the purposes of this definition, *Robots* must meet the following criteria:

1. Contacting the gray tiles within the Zone
2. Not contacting the *Long Barrier*
3. Not contacting any *Elevation Bars*

Elevated – A *Robot* status. A *Robot* is considered *Elevated* at the end of the *Match* if it meets the following criteria:

1. The *Robot* is contacting at least one of the following:
 - a. One or more of their *Alliance's Elevation Bars*
 - b. Any portion of the *Barrier* that is on their *Alliance's* side of the Neutral Zone (i.e., the three black PVC pipes that are attached directly to their *Alliance's Elevation Bars*).
 - c. An *Alliance* partner *Robot* which meets the requirements of points 1-3 in this definition
2. The *Robot* is not contacting any *Field Elements* other than those listed in point 1. This includes gray field tiles, the field perimeter, *Goals*, the opposing *Alliance's Elevation Bar*, etc.
 - a. Contact with (or Possession of) *Triballs* is irrelevant when determining a *Robot's Elevated* status.
3. The *Robot* is not contacting the yellow *Elevation Bar Cap*. (VEX U and VAIRC only)
4. The *Robot* is not contacting an *Alliance* partner *Robot* that is not considered *Elevated*.

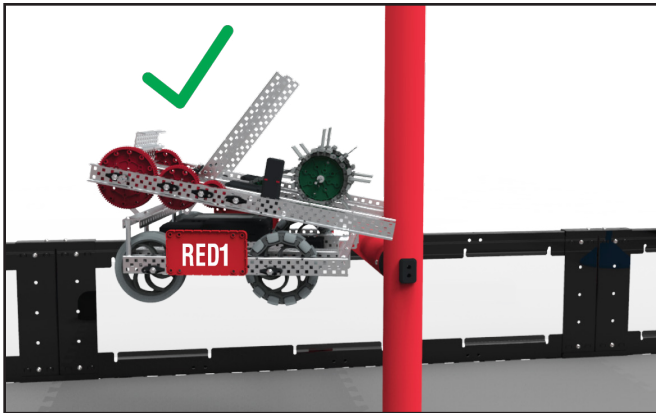

Figure 5: This *Robot* would be considered as *Elevated*, because it meets all the criteria listed above.

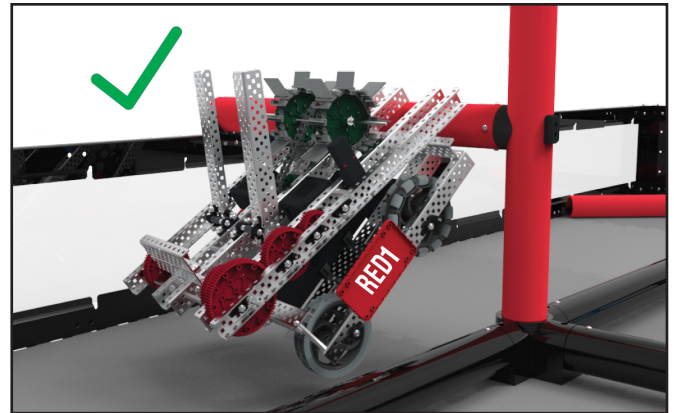

Figure 6: This *Robot* would be considered as *Elevated*, because it meets all the criteria listed above.

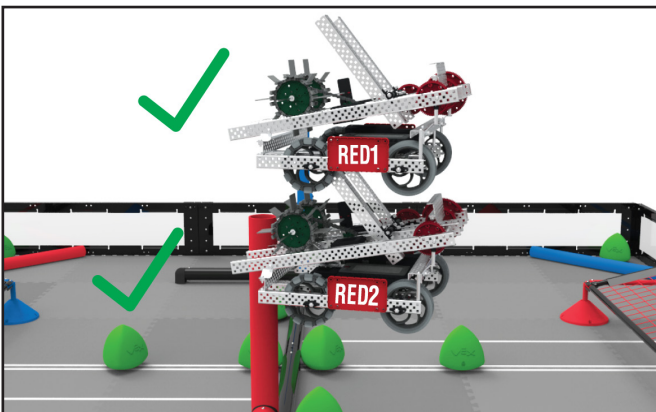

Figure 7: Both *Robots* would be considered as *Elevated*, because they meet all the criteria listed above.

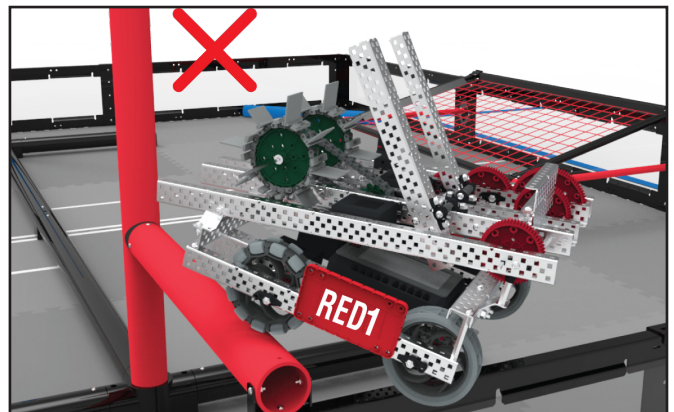

Figure 8: This *Robot* would not be considered as *Elevated*, because it is in contact with the field perimeter.

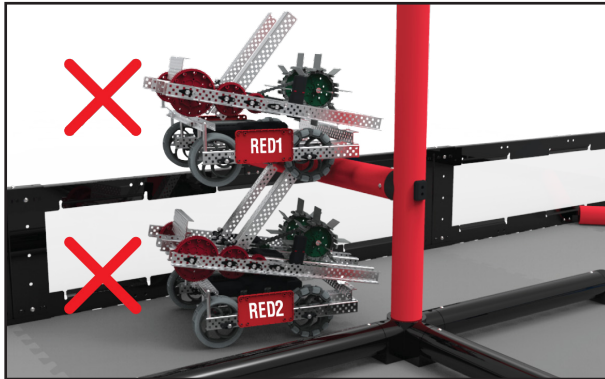

Figure 9: Red Robot 1 is in contact with Red Robot 2, which is still in contact with the field tiles. Therefore, neither Robot would be considered as Elevated.

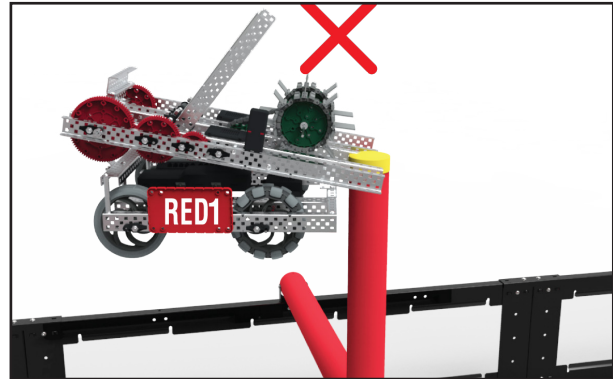

Figure 10: This Robot would not be considered as Elevated in VEX U or VAIRC. In VRC, the Elevation Bar Cap would not be present, and it would be considered Elevated.

Elevation Bar – The Alliance-colored PVC pipes, two red and two blue, at either end of the Barrier.

Elevation Bar Cap – The yellow plastic piece at the top of each set of Elevation Bars. The Elevation Bar Cap is a separate field element and is not considered part of the Elevation Bar.

As of version 3.0 of the Game Manual, *Elevation Bar Caps* have been removed from VRC Head-to-Head and VRC Robot Skills Matches. They should still be used in all VEX U and VAIRC Matches.

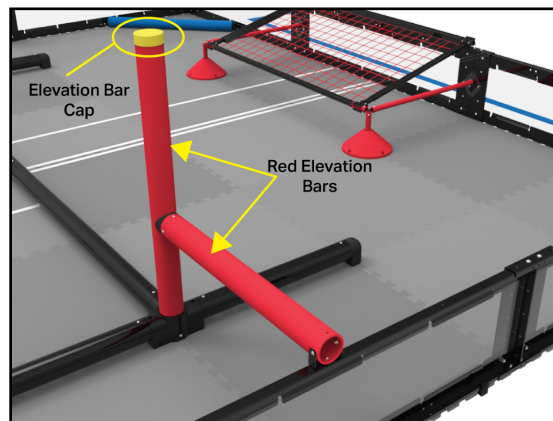

Figure 11: An Elevation Bar and Elevation Bar Cap.

Elevation Tier – A status that represents an *Elevated Robot's* height off of the field at the end of the Match. A Robot's *Elevation Tier* is measured by placing the *Height Guide* vertically next to an *Elevated Robot* and determining which letter-labeled segment of the *Height Guide* the lowest point of the *Robot* falls within (excluding any portion of the *Robot* inside the volume of the *Elevation Bar*). Each white line on the *Height Guide* is considered to be part of the letter-labeled segment immediately below that line. In other words, the *Robot* must be visibly "above the line" in order to move into the next *Elevation Tier*. See Figure 13.

Note: There are no additional Elevation Tiers above the Height Guide. Robots which end the Match above the Height Guide will be considered to be at the maximum, Elevation Tier J.

Note 2: Robots that are not Elevated do not receive an Elevation Tier.

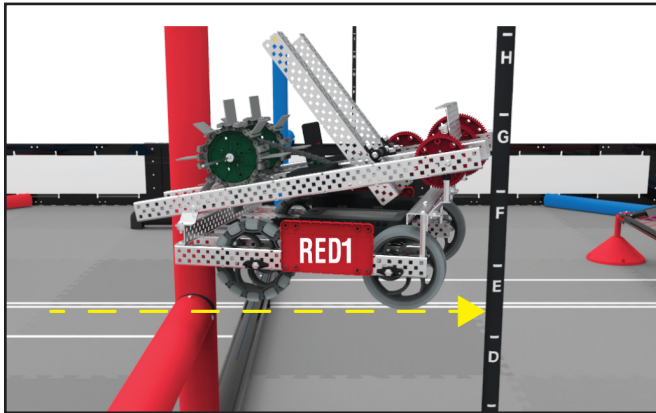

Figure 12: This Robot would be considered to be in Elevation Tier E.

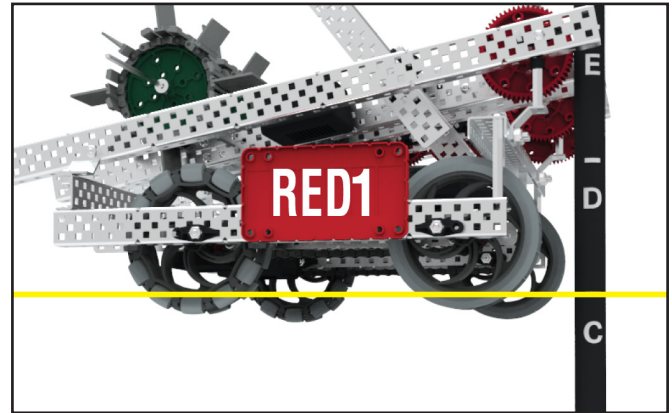

Figure 13: This Robot is not fully above the white line separating Tiers C and D. It would be considered to be in Elevation Tier C.

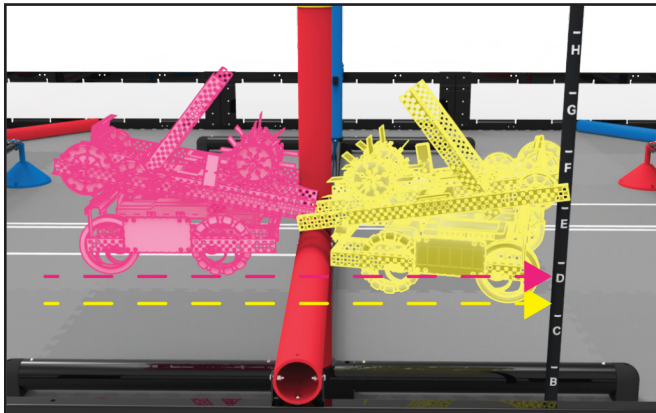

Figure 14: Even though the pink highlighted Robot is slightly higher than the yellow highlighted Robot, they would both still be considered in Elevation Tier D.

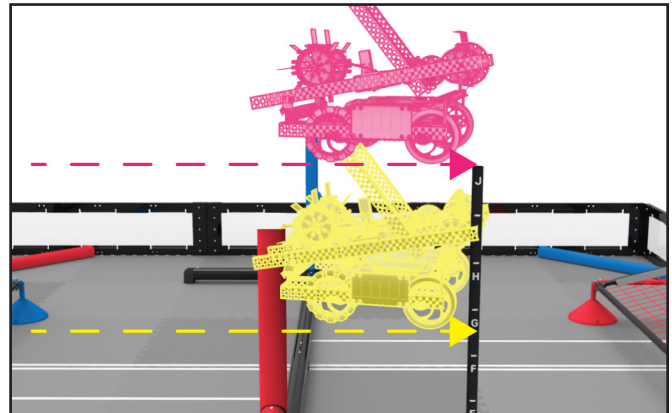

Figure 15: The yellow highlighted Robot would be considered in Elevation Tier G. The pink highlighted Robot would be considered in Elevation Tier J, as there is no higher Tier.

Goal – The *Alliance*-colored, netted structure on either side of the field, one red and one blue, into which *Triballs* can be scored for points.

As a Field Element, the term “Goal” refers to the net and all supporting structures / hardware (e.g. PVC pipes and plastic bases).

As a scoring and gameplay element, the “Goal” refers specifically to the three-dimensional volume bounded by a vertical projection of the outermost PVC pipes onto the field and below the surface of the net.

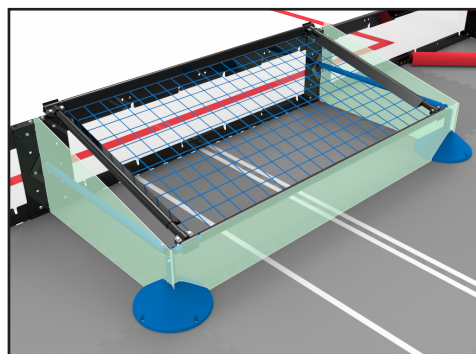

Figure 16: A Goal. The three-dimensional outer scoring boundaries are highlighted in green.

Height Guide – The black PVC pipe, roughly 0.84" in diameter and 36" long, which is labeled with white-printed lettered segments of approximately 3.6" each. The Height Guide is used by Referees to determine *Elevation Tiers* at the end of a *Match*. The *Height Guide* is a tool, not a Field Element.

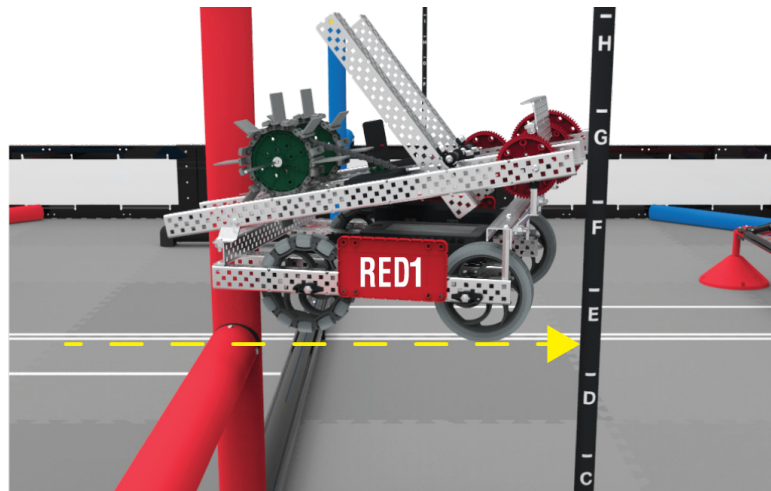

Figure 17: An example of how the Height Guide would be used to determine a Robot's Elevation Tier.

Match Load Bar – The *Alliance*-colored structure, made up of 2" Schedule 40 PVC pipe (with a 2.375" outer diameter) and associated connectors/hardware, that connects diagonally across a corner of the Field.

Match Load Zone – The portion of the floor tile bordered by a *Match Load Bar* and an inside corner of the Field Perimeter.

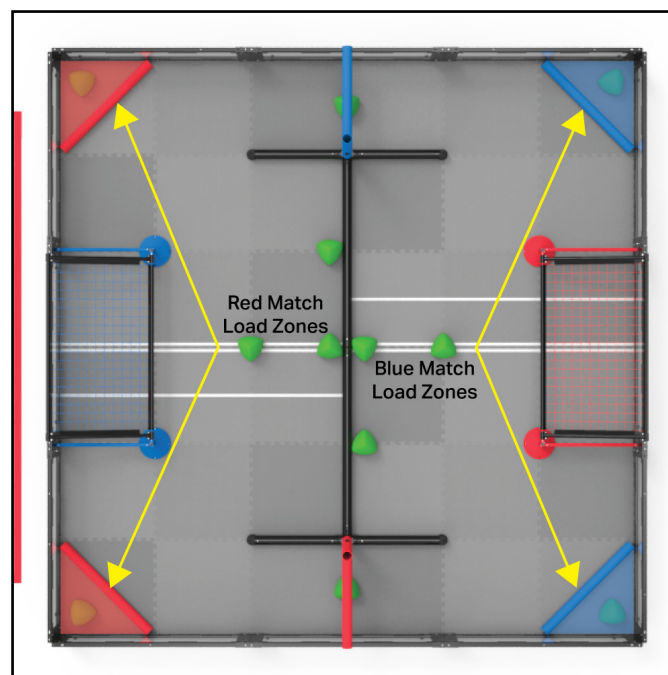

Figure 18: The four (4) Match Load Zones found on a VRC Over Under Field.

Neutral Zone – One of two areas of the field bordered by white tape lines, the *Barrier*, and the field perimeter. The *Neutral Zone* is defined as the gray foam tiles themselves; it is not a 3-dimensional volume.

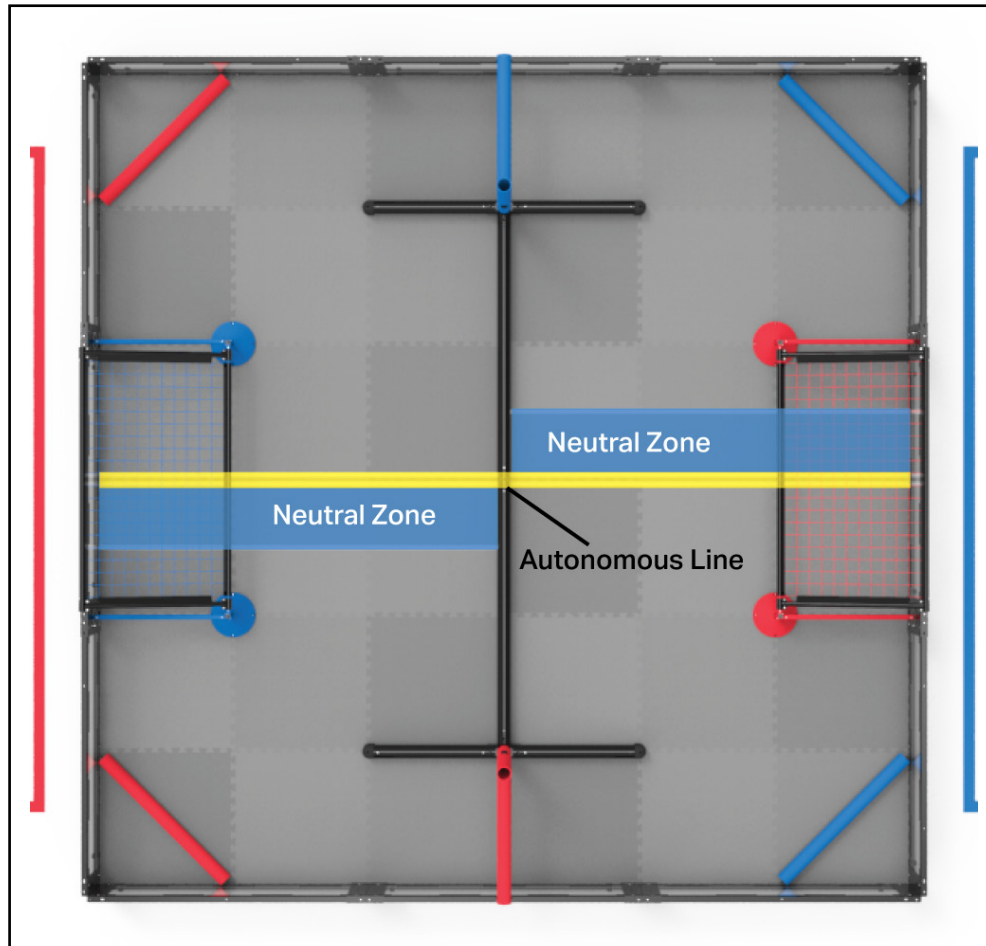

Figure 19: A depiction of the Neutral Zone (blue) and Autonomous Line (yellow) and their boundaries.

Offensive Zone – One of two halves of the field, divided by the *Barrier*. See Figure 20.

- Each *Alliance* has an *Offensive Zone*. An *Alliance's Offensive Zone* is on the side furthest from their *Alliance Station* and closest to that *Alliance's colored Goal*.
- Each *Offensive Zone* consists of the gray foam tiles on one side of the *Barrier*. It is not a 3-dimensional volume.
- The Long *Barrier* is not considered to be in either *Offensive Zone*.
- The *Match Load Zones* are not considered to be part of either *Offensive Zone*.
- The boundary of the *Offensive Zones* below the *Elevation Bars* follows the shape of the interlocking tabs of the Field Tiles.

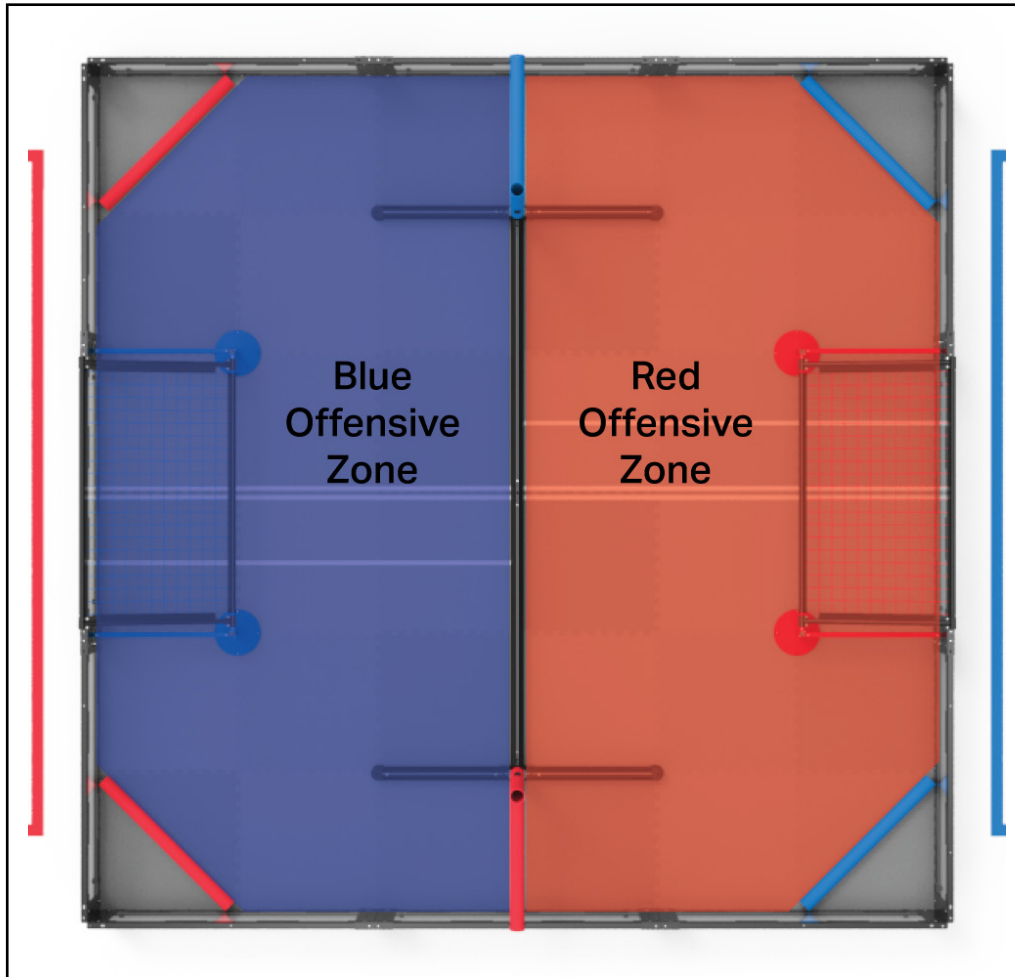

Figure 20: A depiction of the two Offensive Zones and their boundaries.

Plowing - A Robot / Triball status. A Robot is considered to be *Plowing Triballs* if the Robot is intentionally moving them in a preferred direction with a flat or convex face of the Robot.

Possession - A Robot / Triball status. A Robot is considered to be *Possessing a Triball* if a Robot's change in direction would result in controlled movement of the Triball. This typically requires at least one of the following to be true:

1. The Triball is fully supported by the Robot.
2. The Robot is moving the Triball in a preferred direction with a concave face of the Robot (or inside of a concave angle formed by multiple mechanisms/faces of the Robot).

The difference between *Possession* and *Plowing* is analogous to the difference between the terms "controlling" and "moving".

Preload - An Alliance Triball, when loaded into a Robot prior to a Match. See <SG4>.

Scored - A Triball status. See the Scoring section.

Starting Tile – One of the gray foam tiles along the edge of the field perimeter to the right of each *Alliance Station*. See <SG1>.

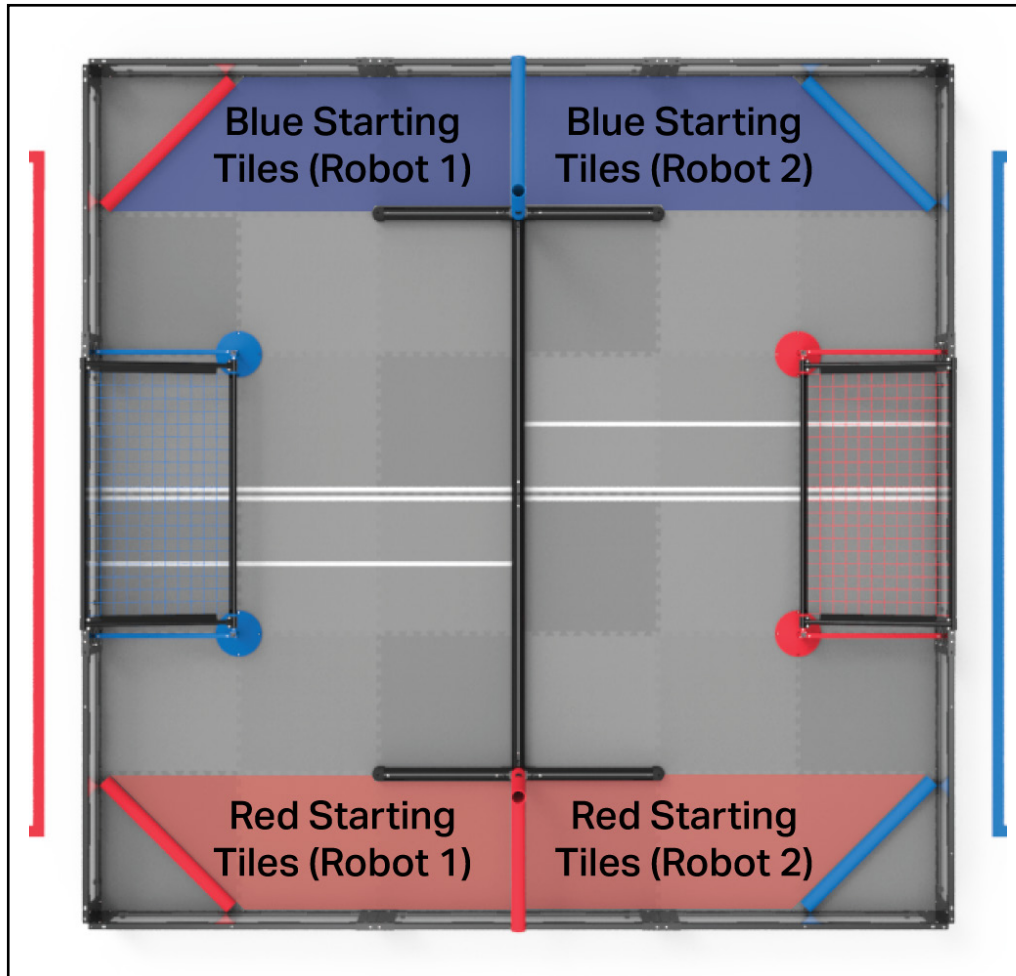

Figure 21: A depiction of the Robot Starting Tiles and their boundaries.

Triball – A green, red, or blue plastic scoring object with a slightly rounded triangular pyramidal shape known as a Reuleaux triangle. Each *Triball* is approximately 6.18" tall with a weight of 103-138g.



Figure 22: The three (3) colors of Triballs used in a VRC Over Under Match.

Scoring

<i>Autonomous Bonus</i>	8 Points
Each <i>Triball</i> Scored in a Goal	5 Points
Each <i>Triball</i> Scored in an <i>Offensive Zone</i>	2 Points
Elevation - Top Tier	20 Points
Elevation - 2nd Tier	15 Points
Elevation - 3rd Tier	10 Points
Elevation - 4th Tier	5 Points

<SC1> All Scoring statuses are evaluated **after the Match ends**. Scores are calculated once all *Triballs*, Field Elements, and *Robots* on the field come to rest.

<SC2> Scoring of the **Autonomous Bonus** is evaluated immediately after the *Autonomous Period* ends (i.e., once all *Triballs*, Field Elements, and *Robots* on the field come to rest).

- a. *Elevation Tier* points are not included in the calculation of an *Alliance's* score for the purposes of determining the *Autonomous Bonus*.
- b. If the *Autonomous Period* ends in a tie, including a zero-to-zero tie, each *Alliance* will receive an *Autonomous Bonus* of four (4) points.
- c. Any rule *Violations*, Major or Minor, during the *Autonomous Period* will result in the *Autonomous Bonus* being awarded to the other *Alliance*. If both *Alliances* violate rules during the *Autonomous Period*, no *Autonomous Bonus* will be awarded.

Note: In general, Minor Violations of SG rules that occur during the Autonomous Period should only affect the outcome of the Autonomous Period (i.e., the Alliance can't win the Autonomous Bonus or earn an Autonomous Win Point) and should not be considered when determining whether a Violation has been repeated during the event.

This does not apply to rule <SG6>; any Match Loads introduced during the Autonomous Period of a VRC head-to-head Match must be recorded as a Violation and assessed to determine whether or note the Violation was Major and/or Match Affecting.

If a Head Referee determines that minor Violations of rules <SG2>, <SG3>, <SG5>, <SG7>, <SG8>, <SG9>, or any "G" rule during the Autonomous Period were intentional/strategic rather than accidental/situational, they should be recorded as Minor Violations and considered when determining whether a Violation has been repeated during the event.

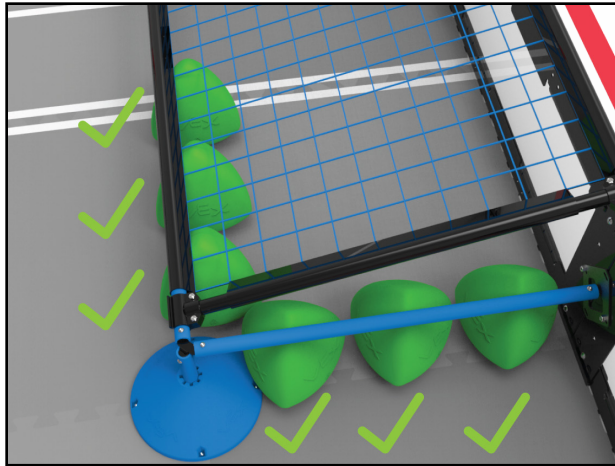

Figure 23: All of these Triballs would be considered as Scored, because two or more of the "Corners" are within the boundary of the Goal.

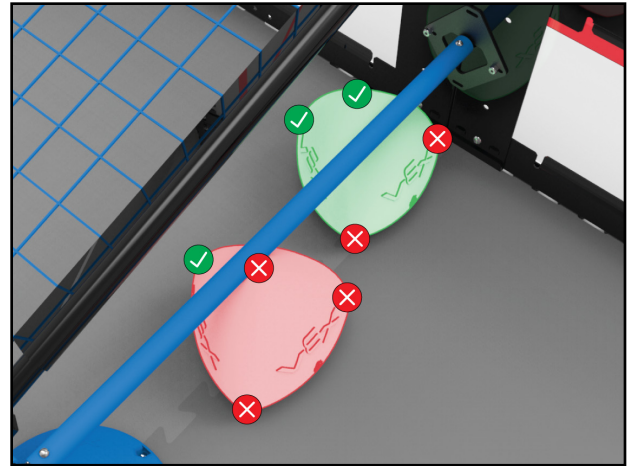

Figure 24: The green highlighted Triball would be considered as Scored, because 2 or more of the "Corners" are within the boundary of the Goal. The red highlighted Triball would not be considered as Scored, because only one "corner" is within the boundary.

<SC3> A Triball is considered **Scored in a Goal** if it meets the following criteria:

- The Triball is not contacting a Robot of the same color Alliance as the Goal.
- At least two (2) corners of the Triball are within the Goal (i.e., are under the Net and have "broken the plane" of the outer edge of the PVC pipes that define the Goal volume).

Note: A Triball that is considered Scored in a Goal is not also considered Scored in that Goal's Offensive Zone.

<SC4> A Triball is considered **Scored in an Offensive Zone** if it meets the following criteria:

- The Triball is not contacting a Robot of the same color Alliance as the Offensive Zone.
- The Triball is contacting the gray foam tiles within the Offensive Zone.

Note: Offensive Zone scoring is based on contact with the gray foam tiles in each Offensive Zone. In the case of any close calls, referees may use a "paper test" (i.e. gently slide a piece of paper under the Triball) to determine which Offensive Zone it should be scored in. If the Triball is contacting both Offensive Zones, then it is not considered Scored in either Zone. See Figure 25.

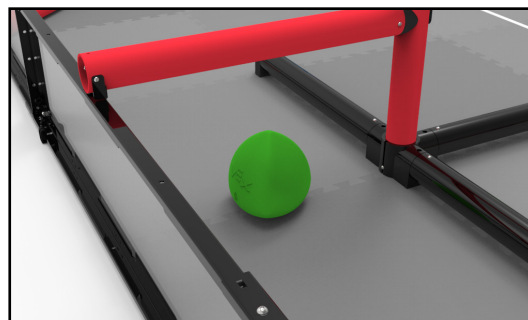

Figure 25: This Triball would not be considered as Scored in either Offensive Zone, because it is touching both zones.

<SC5> **Alliance Triballs** may be Scored in any Goal or Offensive Zone, and always count toward the same color Alliance as the Triball. For example, a red Alliance Triball that meets the definition of Scored in the blue Goal will count as 5 points for the red Alliance.

- a. To be eligible for points, Alliance Triballs must not be contacting any Robots of the same color Alliance as the Triball. Contact with Robots of the opposing Alliance is irrelevant (i.e., rules <SC3a> and <SC4a> do not apply to Alliance Triballs).

<SC6> **Elevation points** are comparative, and are awarded based on the Elevation Tiers achieved by all Robots at the end of the Match. The highest-Elevated Robot will receive the highest number of Elevation points, followed by the second-highest, and so on. If multiple Robots are measured at the same Elevation Tier, they will receive the same amount of points.

Example 1		
Robot	Elevation Tier	Points
Red 1	C	2nd Tier (15)
Red 2	D	Top Tier (20)
Blue 1	A	4th Tier (5)
Blue 2	B	3rd Tier (10)

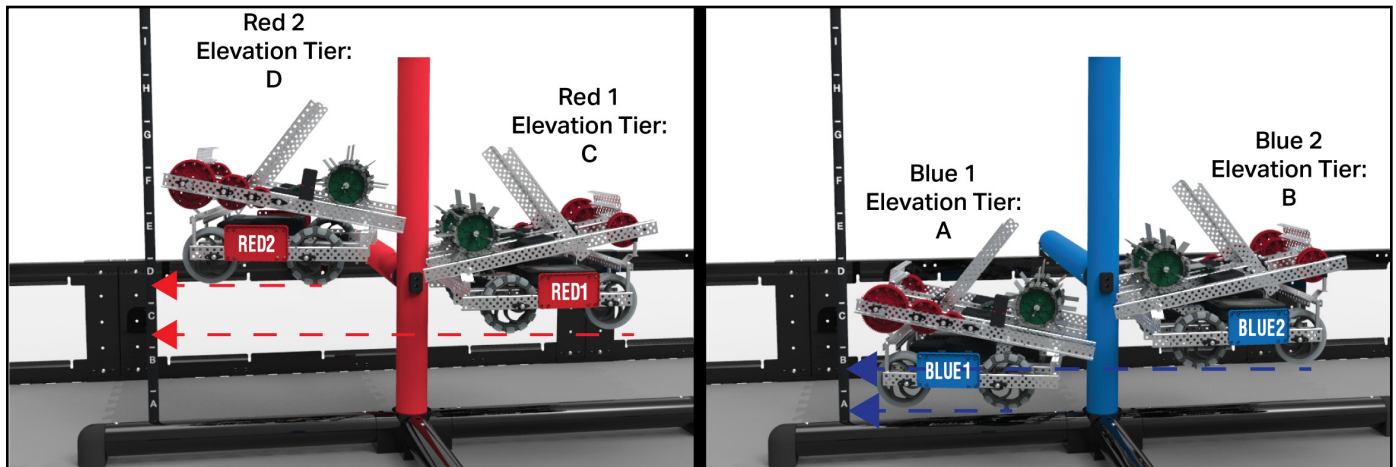

Example 2		
Robot	Elevation Tier	Points
Red 1	None	0
Red 2	F	Top Tier (20)
Blue 1	F	Top Tier (20)
Blue 2	C	2nd Tier (15)

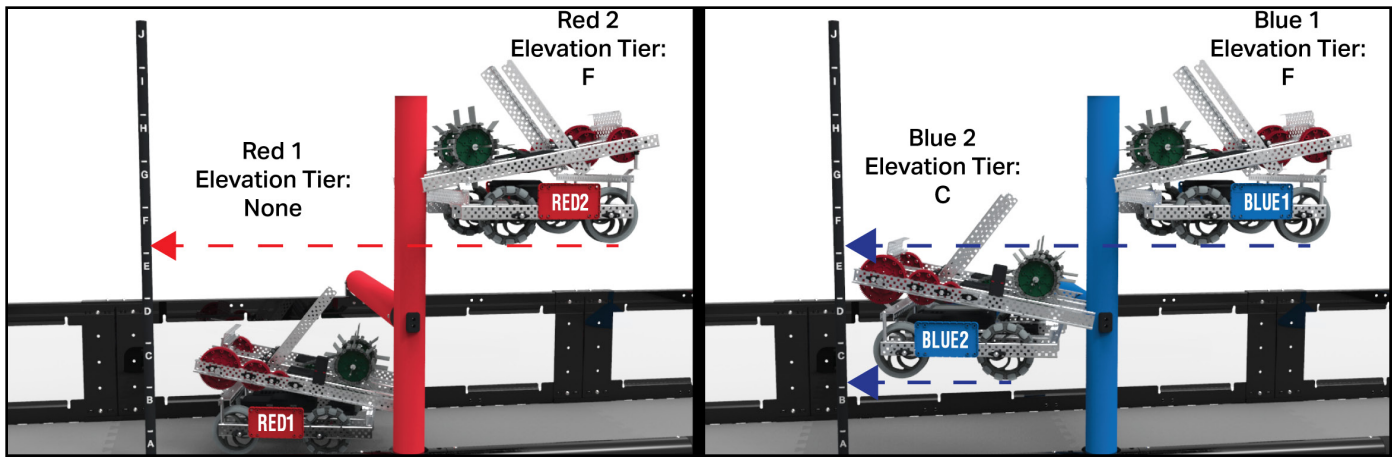

<SC7> An **Autonomous Win Point** is awarded to any *Alliance* that ends the *Autonomous Period* with the following tasks completed:

- Removed the *Triball* from the *Alliance's Match Load Zone* that coincides with their *Starting Tiles*. For example, in Figure 21, the red *Alliance* must remove the *Triball* that begins in the bottom-left *Match Load Zone*, adjacent to *Robot 1's Starting Tiles*.
- Scored at least one of their own *Alliance Triballs* in the *Alliance's own Goal*.
- Ended the *Autonomous Period* with at least one *Robot* contacting their own *Elevation Bar*.
- Not violated any other rules.

Note: Point "a" refers specifically to the actions of the Robot who started near the Match Load Zone in question. To continue the example from Figure 21: if Blue Robot 2 were to launch a Triball into the bottom-left Match Load Zone after one was removed by the red Robot, this would not impact the red Alliance's eligibility to receive the Autonomous Win Point.

Safety Rules

<S1> Be safe out there. If at any time the *Robot* operation or *Team* actions are deemed unsafe or have damaged a Field Element or *Triball*, the offending *Team* may receive a *Disablement* and/or *Disqualification* at the discretion of the *Head Referee*. The *Robot* will require re-inspection as described in rule <R3> before it may take the field again.

Significant Q&As:

- 1808 - [Intentionally/specifically moving a net out of tolerance is a Violation; resulting Triballs in an 'open' Goal should be scored as if the net were in place](#)
- 1990 - [A net that is incidentally lifted during normal Scoring/gameplay is generally not a Violation](#)

<S2> Students must be accompanied by an Adult. No *Student* may attend a VRC event without a responsible *Adult* supervising them. The *Adult* must obey all rules and be careful to not violate Student-centered policies, but must be present at the event in the case of an emergency. *Violations* of this rule may result in removal from the event.

<S3> Stay inside the field. If a *Robot* is completely out-of-bounds (outside the playing field), it will be *Disabled* for the remainder of the *Match*.

Note: The intent of this rule is not to penalize Robots for having mechanisms that inadvertently cross the field perimeter during normal game play. However, mechanisms which cross the field perimeter intentionally and/or repeatedly while interacting with the Match Load Zone may be considered a Violation of <S1> at the Head Referee's discretion.

<S4> Wear safety glasses. All *Drive Team Members* must wear safety glasses or glasses with side shields while in the *Alliance Stations* during *Matches*. While in the pit area, it is highly recommended that all *Team* members wear safety glasses.

General Game Rules

<G1> Treat everyone with respect. All *Teams* are expected to conduct themselves in a respectful and professional manner while competing in VEX Robotics Competition events. If a *Team* or any of its members (*Students* or any *Adults* associated with the *Team*) are disrespectful or uncivil to event staff, volunteers, or fellow competitors, they may be *Disqualified* from a current or upcoming *Match*. *Team* conduct pertaining to <G1> may also impact a *Team's* eligibility for judged awards. Repeated or extreme violations of <G1> could result in a *Team* being *Disqualified* from an entire event, depending on the severity of the situation.

We all can contribute to creating a fun and inclusive event experience for all event attendees. Some examples include:

When dealing with difficult and stressful situations, it is...

- Okay for *Teams* to be gracious and supportive when your *Alliance* partner makes a mistake.
- Not okay for *Teams* to harass, tease, or be disrespectful to your *Alliance* partner when a *Match* does not go your way.

When a *Team* does not understand a *Match* ruling or score, it is...

- Okay for *Drive Team Members* to consult with a *Head Referee* to discuss a ruling per the process outlined in <T3> in a calm and respectful manner.
- Not okay for *Drive Team Members* to continue arguing with the *Head Referees* after a decision has been finalized, or for *Adults* to approach a *Head Referee* with ruling/scoring concerns.

When *Teams* are getting ready for an upcoming *Match*, it is...

- Okay for *Teams* in an *Alliance* to develop a game strategy that utilizes the strengths of both *Robots* to cooperatively solve the game.
- Not okay for *Teams* in an *Alliance* to intentionally play beneath their abilities to manipulate the *Match* results.

This rule exists alongside the REC Foundation Code of Conduct. Violation of the Code of Conduct can be considered a *Major Violation* of <G1> and can result in *Disqualification* from a current *Match*, an upcoming *Match*, an entire event, or (in extreme cases) an entire competition season. The Code of Conduct can be found at <https://vrc-kb.recf.org/hc/en-us/articles/9653987780375-Code-of-Conduct>.

More information regarding the event Code of Conduct process can be found at: <https://vrc-kb.recf.org/hc/en-us/articles/16943747839383-Event-Code-of-Conduct-Process>

Violation Notes: All Violations of <G1> are considered Major Violations and should be addressed on a case-by-case basis. Teams at risk of a <G1> Violation due to multiple disrespectful or uncivil behaviors will usually receive a "final warning", although the Head Referee is not required to provide one.

<G2> VRC is a student-centered program. *Adults* may assist *Students* in urgent situations, but *Adults* may never work on or program a *Robot* without *Students* on that *Team* being present and actively participating. *Students* must be prepared to demonstrate an active understanding of their *Robot's* construction and programming to judges or event staff.

Some amount of *Adult* mentorship, teaching, and/or guidance is an expected and encouraged facet of VEX competitions. No one is born an expert in robotics! However, obstacles should always be viewed as teaching opportunities, not tasks for an *Adult* to solve without *Students* present and actively participating.

When a mechanism falls off, it is...

- Okay for an *Adult* to help a *Student* investigate why it failed, so it can be improved.
- Not okay for an *Adult* to put the *Robot* back together.

When a *Team* encounters a complex programming concept, it is...

- Okay for an *Adult* to guide a *Student* through a flowchart to understand its logic.
- Not okay for an *Adult* to write a premade command for that *Student* to copy/paste.

During *Match* play, it is...

- Okay for an *Adult* to provide cheerful, positive encouragement as a spectator.
- Not okay for an *Adult* to explicitly shout step-by-step commands from the audience.

This rule operates in tandem with the REC Foundation Student Centered Policy, which is available on the REC Foundation website for *Teams* to reference throughout the season:

<https://vrc-kb.recf.org/hc/en-us/articles/9654578622487-Student-Centered-Policy>

Violation Notes: Potential Violations of this rule will be reviewed on a case-by-case basis. By definition, all Violations of this rule become Match Affecting as soon as a Robot which was built by an Adult wins a Match.

<G3> Use common sense. When reading and applying the various rules in this document, please remember that common sense always applies in the VEX Robotics Competition.

For example...

- If there is an obvious typographical error (such as “per <T5>” instead of “per <G5>”), this does not mean that the error should be taken literally until corrected in a future update.
- Understand the realities of the VEX V5 *Robot* construction system. For example, if a *Robot* could hover above the Field for a whole *Match*, that would create loopholes in many of the rules. But... they can't. So don't worry about it.
- When in doubt, if there is no rule prohibiting an action, it is generally legal. However, if you have to ask whether a given action would violate <S1>, <G1>, or <T1>, then that's probably a good indication that it is outside the spirit of the competition.
- In general, *Teams* will be given the “benefit of the doubt” in the case of accidental or edge-case rules infractions. However, there is a limit to this allowance, and repeated or strategic infractions will still be penalized.
- This rule also applies to *Robot* rules. If a component's legality cannot be easily / intuitively discerned by the *Robot* rules as written, then *Teams* should expect additional scrutiny during inspection. This especially applies to those rules which govern non-VEX components (e.g. <R6>, <R7>, <R8>, etc). There is a difference between “creativity” and “lawyering”.

<G4> The Robot must represent the skill level of the Team. Each *Team* must include *Drive Team Members*, *Programmer(s)*, *Designer(s)*, and *Builder(s)*. No *Student* may fulfill any of these roles for more than one VEX Robotics Competition *Team* in a given competition season. *Students* may have more than one role on the *Team*, e.g. the *Designer* may also be the *Builder*, the *Programmer* and a *Drive Team Member*.

- a. *Team* members may move from one *Team* to another for non-strategic reasons outside of the *Team's* control.
 - i. Examples of permissible moves may include, but are not limited to, illness, changing schools, conflicts within a *Team*, or combining/splitting *Teams*.
 - ii. Examples of strategic moves in *Violation* of this rule may include, but are not limited to, one *Programmer* "switching" *Teams* in order to write the same program for multiple *Robots*, or one *Student* writing the Engineering Notebook for multiple *Teams*.
 - iii. If a *Student* leaves a *Team* to join another *Team*, <G4> still applies to the *Students* remaining on the previous *Team*. For example, if a *Programmer* leaves a *Team*, then that *Team's Robot* must still represent the skill level of the *Team* without that *Programmer*. One way to accomplish this would be to ensure that the *Programmer* teaches or trains a "replacement" *Programmer* in their absence.
- b. When a *Team* qualifies for a Championship event (e.g., States, Nationals, Worlds, etc.) the *Students* on the *Team* attending the Championship event are expected to be the same *Students* on the *Team* that was awarded the spot. *Students* can be added as support to the *Team*, but may not be added as *Drive Team Members* or *Programmer* for the *Team*.
 - i. An exception is allowed if one (1) *Drive Team Member* and / or one (1) *Programmer* on the *Team* cannot attend the event. The *Team* can make a single substitution of a *Drive Team Member* or *Programmer* for the Championship event with another *Student*, even if that *Student* has competed on a different *Team*. This *Student* will now be on this new *Team* and may not substitute back to the original *Team*.

Violation Notes: Violations of this rule will be evaluated on a case-by-case basis, in tandem with the REC Foundation Student Centered Policy as noted in <G2>, and the REC Foundation Code of Conduct as noted in <G1>.

Event Partners should bear in mind <G3>, and use common sense when enforcing this rule. It is not the intent to punish a *Team* who may change *Team* members over the course of a season due to illness, changing schools, conflicts within a *Team*, etc.

Event Partners and referees are not expected to keep a roster of any *Student* who has ever been a *Drive Team Member* for one day. This rule is intended to block any instance of loaning or sharing *Team* members for the sole purpose of gaining a competitive advantage.

<G5> Robots begin the Match in the starting volume. At the beginning of a *Match*, each *Robot* must be smaller than a volume of 18" (457.2 mm) long by 18" (457.2 mm) wide by 18" (457.2 mm) tall.

Note: Using external field influences, such as Preloads or the field perimeter wall, to maintain a Robot's starting size is only acceptable if the Robot would still satisfy the constraints of <R4> and pass inspection without these influences.

Violation Notes: Any Violation of this rule will result in the Robot being removed from the field prior to the start of the Match, and rules <R3d> and <T5> will apply until the situation is corrected.

<G6> Keep your Robots together. Robots may not intentionally detach parts during the *Match* or leave mechanisms on the field.

Note: Parts which become detached unintentionally and therefore a Minor Violation are no longer considered "part of a Robot," and should be ignored for the purposes of any rules which involve Robot contact or location (e.g., Scoring, Double-Zone, etc.) or Robot size.

Violation Notes: Major Violations of this rule should be rare, as Robots should never be designed to intentionally violate it. Minor Violations are usually due to Robots being damaged during gameplay, such as a wheel falling off.

<G7> Don't clamp your Robot to the field. Robots may not intentionally grasp, grapple, or attach to any Field Elements. Strategies with mechanisms that react against multiple sides of a Field Element in an effort to latch or clamp onto said Field Element are prohibited. The intent of this rule is to prevent *Teams* from both unintentionally damaging the field and/or from anchoring themselves to the field.

Note: An Alliance's own Elevation Bars and Match Load Bars are exceptions to this rule, i.e., there is no penalty for clamping onto them.

Violation Notes: Major Violations of this rule should be rare, as Robots should never be designed to intentionally violate it.

<G8> Only Drivers, and only in the Alliance Station. During a *Match*, each *Team* may have up to three (3) *Drive Team Members* in their *Alliance Station*, and all *Drive Team Members* must remain in their *Alliance Station* for the duration of the *Match*.

Drive Team Members are prohibited from any of the following actions during a *Match*:

- a. Bringing/using any sort of communication devices into the *Alliance Station*. Devices with communication features turned off (e.g., a phone in airplane mode) are allowed.
- b. Standing on any sort of object during a *Match*, regardless of whether the field is on the floor or elevated.
- c. Bringing/using additional materials to simplify the game challenge during a *Match*.
- d. To ensure that *Drive Team Members* are aware of verbal calls or warnings during a *Match* (as an application of rules <T1>, <G1>, <S1>, and <G3>), powered headphones, earbuds, and passive earpieces connected to electronic devices cannot be worn/used in the *Alliance Station* except as required by an officially approved accommodation request.

<G8c> is intended to refer to non-*Robot*-related items that directly influence gameplay, such as using a fan to influence opponent *Triballs* traveling through the air. Provided no other rules are violated, and the items do not pose any safety or field damage risks, the following examples are not considered violations of <G8>:

- Materials used before or after a *Match*, such as a pre-*Match* alignment aid, or a carrying case for *Robots* / *Controllers*
- Strategic aids, such as a whiteboard or clipboard
- Earplugs, gloves, or other personal accessories

Note: Drive Team Members are the only Team members that are allowed to be in the Alliance Station during a Match.

Note 2: During a Match, Robots may be operated only by the Drive Team Members and/or by software running on the Robot's control system, in accordance with <R26> and <G10>.

Violation Notes: Major Violations of this rule are not required to be Match Affecting, and could invoke Violations of other rules, such as <G1>, <G2>, or <G4>.

Significant Q&As

- 1538 - [Teams can't provide their own tools to store/manage Triballs at the field](#)

<G9> Hands out of the field. *Drive Team Members* are prohibited from making intentional contact with any *Triballs*, *Field Elements*, or *Robots* during a *Match*, apart from the contact specified in <G9a>.

- a. During the *Driver Controlled Period*, *Drive Team Members* may only touch their own *Robot* if the *Robot* has not moved at all during the *Match*. Touching the *Robot* in this case is permitted only for the following reasons:
 - i. Turning the *Robot* on or off.
 - ii. Plugging in a battery.
 - iii. Plugging in a V5 Robot Radio.
 - iv. Touching the V5 Robot Brain screen, such as to start a program.
- b. *Drive Team Members* are not permitted to break the plane of the field perimeter at any time during the *Match*, apart from the actions described in <G9a>, <SG3>, and <SG6>.
- c. Transitive contact, such as contact with the field perimeter that causes the field perimeter to contact *Field Elements* or *Triballs* inside of the field, could be considered a *Violation* of this rule.

Note: Any concerns regarding Field Element or Triball starting positions should be raised with the Head Referee prior to the Match. Team members may never adjust the Triballs or Field Elements themselves, except for Match Load Zone Triballs as described in <SG1>.

Significant Q&As

- 1953 - [Contacting the Field Perimeter to affect a Robot's Elevation is a Violation](#)

<G10> Controllers must stay connected to the field. Prior to the beginning of each *Match*, *Drive Team Members* must plug their V5 Controller into the field's control system. This cable must remain plugged in for the duration of the *Match*, and may not be removed until the "all-clear" has been given for *Drive Team Members* to retrieve their *Robots*. See <T23> for more information regarding field control system options.

Violation Notes: The intent of this rule is to ensure that Robots abide by commands sent by the tournament software. Temporarily removing the cable to assist with mid-Match troubleshooting, with an Event Partner or other event technical staff present and assisting, would not be considered a Violation.

<G11> Autonomous means "no humans." During the *Autonomous Period*, *Drive Team Members* are not permitted to interact with the *Robots* in any way, directly or indirectly. This could include, but is not limited to:

- Activating any controls on their V5 Controllers
- Unplugging or otherwise manually interfering with the field connection in any way
- Manually triggering sensors (including the Vision Sensor) in any way, even without touching them

Note: In extreme cases, with permission from the Head Referee, Teams may disable their Robot during the Autonomous Period by holding the power button on their V5 Controller. This exception is only intended for egregious safety- or damage-related circumstances; disabling an autonomous routine for strategic purposes would still be considered a Violation of <G11>. See this Q&A post for more details: <https://www.robotevents.com/VRC/2023-2024/QA/1685>

Violation Notes: See <G12>.

<G12> All rules still apply in the Autonomous Period. Teams are responsible for the actions of their *Robots* at all times, including during the *Autonomous Period*. Any *Violations* committed during the *Autonomous Period* that affect the outcome of the *Autonomous Bonus*—whether they are *Match Affecting* or not—will result in the *Autonomous Bonus* being automatically awarded to the opposing *Alliance*.

If both *Alliances* commit *Violations* during the *Autonomous Period* that would have affected the outcome of the *Autonomous Bonus*, then no *Autonomous Bonus* will be awarded.

Violation Notes: The intent of this rule is to provide retribution for Violations committed during the Autonomous Period that are not Match Affecting, and therefore not Major Violations, but do affect the outcome of the Autonomous Bonus.

<G13> Don't destroy other Robots. But, be prepared to encounter defense. Strategies aimed solely at the destruction, damage, tipping over, or *Entanglement* of opposing *Robots* are not part of the ethos of the VEX Robotics Competition and are not allowed.

- a. VRC Over Under is intended to be an offensive game. *Teams* that partake in solely defensive or destructive strategies will not have the protections implied by <G13> (see <G14>). However, defensive play which does not involve destructive or illegal strategies is still within the spirit of this rule.
- b. VRC Over Under is also intended to be an interactive game. Some incidental tipping, *Entanglement*, and damage may occur as a part of normal gameplay without violation. It will be up to the *Head Referee's* discretion whether the interaction was incidental or intentional.
- c. A *Team* is responsible for the actions of its *Robot* at all times, including the *Autonomous Period*. This applies both to *Teams* that are driving recklessly or potentially causing damage, and to *Teams* that drive around with a small wheel base. A *Team* should design its *Robot* such that it is not easily tipped over or damaged by minor contact.

Violation Notes:

- *Major Violations of this rule are not required to be Match Affecting. Intentional and/or egregious tipping, Entanglement, or damage may be considered a Major Violation at the Head Referee's discretion.*
- *Repeated Violations within a Match or tournament could be considered a Violation of <G1> and/or <S1> at the Head Referee's discretion.*

Significant Q&A's

- 1628 - [Re-righting a Tipped opponent might help minimize a Violation](#)
- 1731 - [Deciding whether Tipping is intentional or incidental](#)
- 1868 - [Using a ramp to tip an opponent is probably intentional Tipping](#)

<G14> Offensive Robots get the "benefit of the doubt." In a case where *Head Referees* are forced to make a judgment call regarding a destructive interaction between a defensive and offensive *Robot*, or an interaction which results in a questionable *Violation*, referees will decide in favor of the offensive *Robot*.

<G15> You can't force an opponent into a penalty. Intentional strategies that cause an opponent to break a rule are not permitted, and will not result in a *Violation* for the opposing *Alliance*.

Violation Notes: In most cases, if a Team causes their opponent to break a rule, the Head Referee will simply not enforce the penalty on that opponent, and it will be considered a Minor Violation for the guilty Team. However, if the forced situation becomes Match Affecting in favor of the guilty Team, it will be considered a Major Violation.

<G16> No Holding for more than a 5-count. A *Robot* may not *Hold* an opposing *Robot* for more than a 5-count during the *Driver Controlled Period*.

For the purposes of this rule, a "count" is defined as an interval of time that is approximately one second in duration, and "counted-out" by *Head Referees* verbally.

A *Holding* count is over when at least one of the following conditions is met:

- a. The two *Robots* are separated by at least two (2) feet (approximately one foam tile).
- b. Either *Robot* has moved at least two (2) feet away (approximately 1 tile) from the location where the *Trapping* or *Pinning* count began.
 - i. In the case of *Lifting*, this location is measured from where the *Lifted Robot* is released, not from where the *Lifting* began.
- c. The *Holding Robot* becomes *Trapped* or *Pinned* by a different *Robot*.
 - i. In this case, the original count would end, and a new count would begin for the newly Held *Robot*.
- d. In the case of *Trapping*, if an avenue of escape becomes available due to changing circumstances in the *Match*.

After a *Holding* count ends, a *Robot* may not resume *Holding* the same *Robot* again for another 5-count. If a *Team* resumes *Holding* the same *Robot* within that 5-count, the original count will resume from where it ended.

Significant Q&A's

- 1708 - [Robot stuck on a Match Load Bar is not necessarily a Violation](#)
- 1842 - [Goals are not considered avenues of escape from Trapping](#)

<G17> Use Triballs to play the game. *Triballs* may not be used to accomplish actions that would be otherwise illegal if they were attempted by *Robot* mechanisms (e.g., interfering with an opponent's Autonomous routine per <SG9>.)

The intent of this rule is to prohibit *Teams* from using *Triballs* as "gloves" to loophole any rule that states "a *Robot* may not [do some action]". This rule is not intended to be taken in its most extreme literal interpretation, where any interaction between a *Triball* and a *Robot* needs to be scrutinized with the same intensity as if it were a *Robot*.

Violation Notes: If a rule is Violated through the use of Triballs instead of a Robot mechanism, it should be evaluated as though the rule in question had been Violated by a Robot mechanism.

Specific Game Rules

<SG1> **Starting a Match.** Prior to the start of each *Match*, the *Robot* must be placed such that it is:

- a. Contacting at least one (1) of their *Alliance's Starting Tiles*. See Figure 26.
- b. Not contacting any *Starting Tiles* in the same *Offensive Zone* as their *Alliance* partner. One *Robot* must be in the red *Offensive Zone*, and one must be in the blue *Offensive Zone*. See Figure 20.
- c. Not contacting any other gray foam field tiles, including the *Match Load Zones*.
- d. Not contacting any *Triballs* other than a maximum of one (1) *Preload*. See rule <SG4>.
- e. Not contacting any other *Robots*.
- f. Not contacting any *Barriers* or *Elevation Bars*.
 - i. Contact with the field perimeter and/or *Match Load Bars* is permitted, but not required.
- g. Completely stationary (i.e., no motors or other mechanisms are in motion).

Note: The Triballs which start in each Match Load Zone must be contacting the Match Load Zone at the start of the Match. However, they may be repositioned during pre-Match setup by the Team whose Robot is using the Starting Tiles adjacent to that Match Load Zone. For example, in Figure 26, Red Robot 1 would be permitted to reposition the Triball in the lower-left red Match Load Zone.

Violation Notes: The Match will not begin until the conditions in this rule are met. If a Robot cannot meet these conditions in a timely manner, the Robot will be removed from the field and rules <R3d> and <T5> will apply until the situation is corrected.

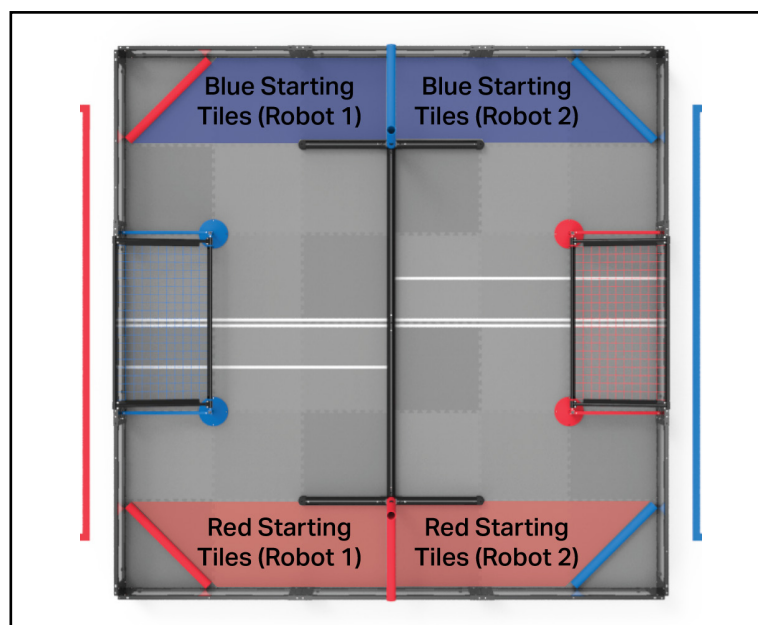

Figure 26: The tiles in which Robots can start a Match.

<SG2> Horizontal expansion is limited. Once the *Match* begins, *Robots* may expand, but no horizontal dimension may exceed 36" (914.4 mm) at any point during the *Match*.

- This limit refers to "horizontal" expansion measured between any two points of the *Robot*, including diagonals, relative to the playing field (i.e., it does not "rotate with the *Robot*").
- There is no height limit on *Robot* expansion.

The following visual references on the field may be used by *Head Referees* when making in-*Match* judgment calls:

- Diagonal of a single field tile (~34")
- Distance from the *Barrier* to the *Neutral Zone's* single white tape line (~34.5")
- Width between *Goal* bases (~39.4")

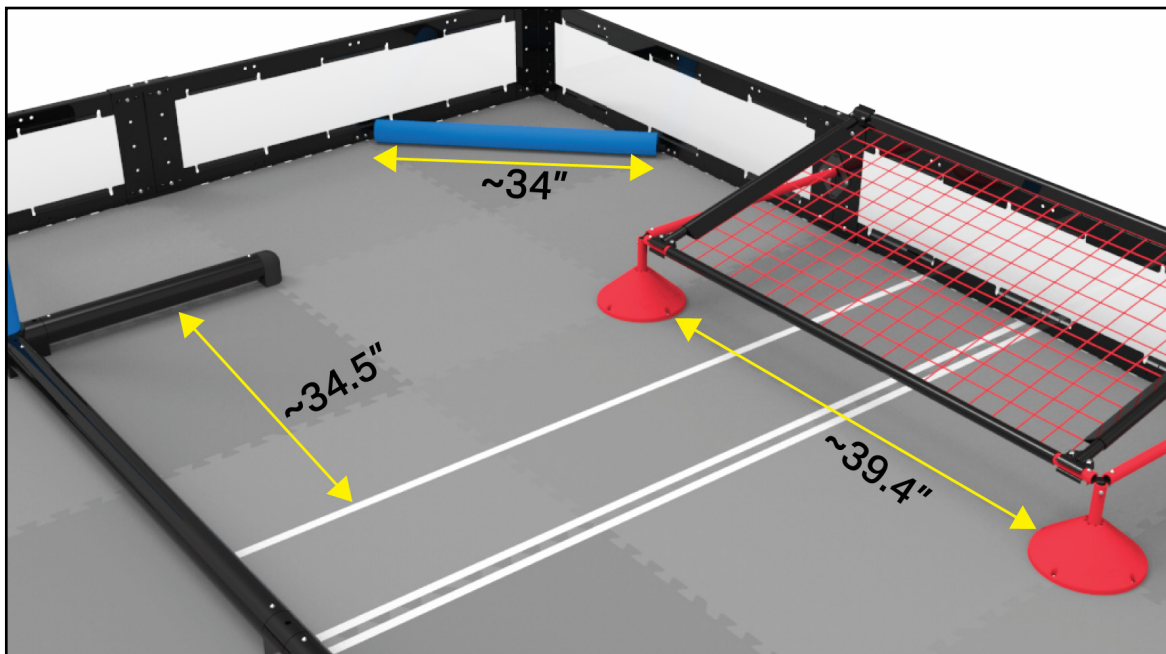

Figure 27: Visual references for a *Head Referee* to determine if a *Robot* has exceeded the maximum expansion limit.

Violation Notes:

- *The primary intent of this rule is to limit defensive horizontal expansion. As such, Robots who choose to expand horizontally in the vicinity of opponent Goals or Match Load Bars may be subject to rule <G14>, and will not receive the "benefit of the doubt" in the case of any Head Referee judgment calls.*
- *Because Elevation is an inherently offensive action, a greater "benefit of the doubt" will be applied to momentary/accidental Minor Violations of this rule during Elevation.*

<SG3> Keep Triballs in the field. Teams may not intentionally remove *Triballs* from the field. Although *Triballs* may accidentally leave the field, doing so intentionally or repeatedly would be a *Violation* of this rule.

Triballs that leave the field during *Match* play, whether intentionally or unintentionally, will be returned to the field by being placed in a *Match Load Zone* nearest the point at which they exited.

- a. Referees will return *Triballs* to the field when it is deemed safe to do so, at their discretion.
- b. This action is not considered a "Match Load", i.e., the stipulations in rule <SG6> do not apply. For example, the *Triball* cannot be placed directly onto a *Robot*.
- c. Incidental contact with other *Triballs* that are already in the *Match Load Zone* may occur, although referees will make a concerted effort not to do so.
- d. The *Triball* may be placed on top of other *Triballs* that are already in the *Match Load Zone* if necessary, e.g., if *Triballs* are already covering the entire *Match Load Zone* foam tile region.
- e. At their discretion, referees may also direct a nearby *Drive Team Member* or other volunteer to return the *Triball* to a specific *Match Load Zone*. However, this should never be done by *Drive Team Members* proactively without referee acknowledgment.

Note: Triballs which come to rest on top of a Goal may be retrieved by a Drive Team Member from the Alliance Station adjacent to the Goal in question. The Triball is then considered a Match Load for the Alliance who retrieved the Triball. This momentary interaction is an exception to rule <G9>.

Significant Q&As:

- 1536 - [Intentionally placing Triballs on the net counts as removing them from the field](#)
- 1809 - [Deflecting Triballs back into the Field is a Violation of rule <G9>](#)

<SG4> Each Robot gets one Alliance Triball as a Preload. Prior to the start of each *Match*, each *Alliance Triball / Preload* that is used must be placed such that it is:

- a. Contacting one *Robot* of the same *Alliance* color as the *Preload*.
- b. Not contacting the same *Robot* as another *Preload*.
- c. Fully within the field perimeter.

If a *Team* does not wish to use their *Preloads*, or if a *Robot* is not present for their *Match*, then the *Preloads* may be used as *Match Load Triballs* in accordance with <SG6>.

Violation Notes: See <SG1>.

<SG5> Stay away from nets on the Goals. Becoming *Entangled* with the net on either *Goal* is considered a violation of <S1> and/or <G7>, and will result in a *Disablement*. Causing an opponent to become *Entangled* with the net is considered a violation of <G15> and, at a minimum, will result in a *Disablement* for both *Teams*.

This rule is a specific exception to <G15>. Normally, under <G15>, a *Robot* which is forced into breaking a rule (such as being pushed into the net) is not penalized. However, because heavy *Robot-to-Robot* interaction is expected around the *Goals*, and *Entanglement* carries a high risk of playing field damage, any *Robot* that becomes *Entangled* must be *Disabled* regardless of fault. *Robots* are responsible for their own actions and mechanism designs.

If this occurs during the *Autonomous Period*, the *Head Referee* should assess the severity of the *Entanglement* once the *Autonomous Period* ends. If they determine that the risk of field damage is low, they have the option to grant a 5-second “grace period” to free themselves at the beginning of the *Driver Controlled Period*.

This exception is only permitted at the *Head Referee’s* discretion, and is only valid if it is verbally communicated to *Drive Team Members* before the start of the *Driver Controlled Period*. If the *Team* is unable to free their *Robot* after 5 seconds, this rule will take effect and the *Robot* must be *Disabled*.

Note: Lifting the net structure in an attempt to add or remove Triballs is considered a Violation of <SG5>, and may also be considered a Violation of <G7>, and/or <S1> at the Head Referee’s discretion.

Violation Notes:

- *Momentary or incidental contact is expected and is not considered a Violation or Disablement. The rule only becomes invoked once a Robot has become Entangled with a net and the Head Referee wishes to avoid potential field damage.*
- *The Disablement associated with this rule is not considered a Major Violation. It is intended to be an avenue for the Head Referee to prevent any potential safety concerns and/or damage to the net.*
- *Intentional, strategic, or repeated Minor Violations and/or Disablements may escalate to a Major Violation at the Head Referee’s discretion.*
- *Disablements last for the remainder of the match, regardless of whether the status that led to Disablement is resolved or not.*

<SG6> Match Load Triballs may be safely introduced during the Match under certain conditions.

For the purpose of this rule, “introduce” refers to the moment when a Match Load *Triball* is no longer in contact with a human and has crossed the plane of the field perimeter.

During this action, a *Drive Team Member’s* hand may temporarily break the plane of the field perimeter. This momentary interaction is an exception to rule <G9>. Excessive, unnecessary, or unsafe actions while introducing a Match Load may be considered a *Violation* of <S1> and/or <G1> at the *Head Referee’s* discretion.

Teams are responsible for the actions of their own *Robots* at all times, including while interacting with Match Load strategies/mechanisms that could be deemed unsafe. A higher “benefit of the doubt” will be granted to *Teams* who can demonstrate any precautions or considerations that have been taken to minimize this risk, e.g., during inspection or a practice match. See [this Q&A post](#) for more information.

Match Load *Triballs* may be introduced by a *Drive Team Member* in one of two ways:

1. By placing the Match Load gently onto a *Match Load Zone*. This may be done at any time during the *Driver Controlled Period*, provided that no other rules are Violated.
 - a. “Throwing,” “rolling,” or otherwise imparting enough energy onto a *Triball* such that it bounces out of the *Match Load Zone* is not permitted.
 - b. Note that the *Match Load Zone* refers to the foam tile itself; it is not a three-dimensional volume. There is no rules-bound limit for how many *Triballs* may be in the *Match Load Zone* at any given time, provided that new Match Loads are placed directly onto the foam tile without violating any other rules.
2. By placing the Match Load gently into / onto a *Robot* from the *Drive Team Member’s Alliance*.
 - a. The *Robot* must be contacting the *Match Load Zone* or the *Match Load Bar*.
 - b. Momentarily / accidentally losing contact with the *Match Load Zone* or *Match Load Bar* is permissible, provided that the *Robot* is still “breaking the plane” of the inside edge of the *Match Load Bar*. See Figure 28.
 - c. Rules <S1> and <S3> still apply to this interaction; there should be no reason for a *Robot* to extend outside of the field perimeter during this action.
 - d. The following actions are not considered “placing the Match Load gently onto a *Robot*”, and are not permitted. Egregious, intentional, or repeated instances of the following actions may become <G9> *Violations* at the *Head Referee’s* discretion.
 - i. “Throwing,” “rolling,” or otherwise imparting enough energy onto a *Triball* such that its motion after release is mostly defined by the human (instead of the *Robot*).
 - ii. Physically interacting with the *Robot*, such as pushing down on a mechanism (using a sensor to detect a *Triball* is permitted).
 - iii. Placing the Match Load such that it is in contact with anything other than the *Robot*, such as the field perimeter or gray foam tiles.

Figure 28: This *Robot* is not physically touching the *Match Load Bar*, but is still breaking the plane of the inside edge of the *Match Load Bar*.

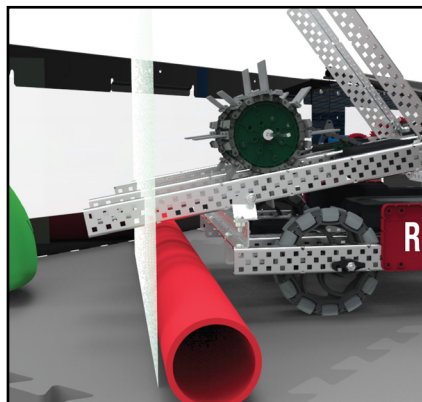

The intent of part 2b is to provide some “benefit of the doubt” to *Teams* for incidental *Violations* that may occur during rapid introduction of Match Loads. For the purposes of this rule, “momentary” refers to a duration of 2 seconds or less.

Part 2a should still be the primary driver of *Robot* design; part 2b is not intended to permit a design which relies solely on “breaking the plane” with no intent of the *Robot* ever contacting the *Match Load Bar*. In other words, it is still the *Team’s* responsibility to ensure that a *Head Referee* can clearly determine their legality “at a glance” during a *Match*.

Part 2d is intended to provide a reasonable, limited scope of prohibited Match Load actions. See [this Q&A post](#) for more information.

Note: Match Load Triballs may only be introduced once the Driver Controlled Period has begun. During the Autonomous Period, and during the time between the Autonomous and Driver Controlled Periods, Match Load Triballs may not cross the plane of the field perimeter.

Note 2: Match Loads must be introduced to the field one at a time.

Violation Notes:

- a. *For the purposes of Match Affecting calculations, each illegal Match Load should be considered worth a value of 2 points. These values are not added to the actual score. As with all Match Affecting calculations, only the winner’s points should be considered.*

Match Score	Score Difference	# of Illegal Match Loads	“Match Affecting” Difference	Result
Red: 50	+1 (Red)	4	+8 (Red)	Yes, Match Affecting
Blue: 49		3		
Red: 55	+5 (Red)	4	+8 (Red)	Yes, Match Affecting
Blue: 50		3		
Red: 62	+12 (Red)	3	+6 (Red)	No, not Match Affecting
Blue 50		5		
Red: 50	0	4	+8 (Red)	Yes, Match Affecting (Red)*
Blue: 50		3	+6 (Blue)	

** Note: This scenario is a specific application / exception for how <T8> should be applied to <SG6>.*

- b. *For the purposes of this rule, the following guidelines should be used for escalating repeated Minor Violations to a Major Violation during Qualification Matches:*
 1. *Six or more illegal Match Loads in a single Qualification Match.*
 2. *Three or more Qualification Matches with at least one illegal Match Load (i.e., the third Match and all subsequent Matches with a Violation).*
- c. *For the purposes of this rule, only Match Affecting Violations should be considered during Elimination Matches (i.e., repeated <SG6> Minor Violations in Elimination Matches do not compound to Major Violations).*

1. *Point B-1 does not explicitly apply during Elimination Matches, although the risk of illegal Match Loads becoming Match Affecting still inherently increases as the quantity of Match Loads increases.*
2. *Point B-2 does not apply during Elimination Matches.*

Significant Q&As:

- 1550 - [Match Loads must be entered from the Alliance Station wall](#)
- 1589 - [You cannot push down on a Robot/mechanism while introducing Match Loads](#)
- 1777 - [How to judge whether a Match Load maneuver is safe](#)
- 1778 - [Legality of Match Load strategies / designs](#)
- 1789 - [Only one Match Load can break the plane of the field per Match Load Zone at a time](#)
- 1821 - [A Match Load can only be introduced after the previous one is "launched"](#)
- 1836 - [Referees should warn Teams before and after bad Match Loads whenever possible](#)
- 1849 - [Reaching more than a tile into the field repeatedly may be called as a Violation](#)
- 1938 - [An individual can use both hands to safely introduce one Triball at a time](#)
- 1973 - [When possible, Match Load Violations are assigned to the human Match Loader's team](#)

<SG7> Possession is limited to one (1) Triball. *Robots may not have greater-than-momentary Possession of more than one Triball at once. Robots in Violation of this rule must immediately stop all Robot actions except for attempting to remove the excess Triball(s). This rule applies to both intentional and accidental Possession.*

The intent of this rule is not to punish *Robots* for pushing *Triballs* that are in their way; that is, *Robots* are free to incidentally drive through *Triballs* on the field while *Possessing* a *Triball*.

Violation Notes:

- *Any intentional Violation by an Alliance who wins the Match will be considered Match Affecting.*

Examples of egregious Violations that may immediately escalate to Major Violations include, but are not limited to:

- *Continuing to play other portions of the game (e.g., defensive maneuvers, Elevating) without attempting to remove excess Triballs for the majority of the Match*
- *"Accidentally" Possessing an egregious amount of Triballs*
- *"Removing" excess Triballs directly into a Team's own Goal*

Note: There are no rules prohibiting Plowing multiple Triballs. However, Robots which employ Plowing strategies should be cognizant of any accidental Possession risks while doing so, such as a Triball rolling into an intake mechanism while another one is already there.

Note 2: When removing excess Triballs, the safest maneuver will always be to remove them into an opponent's Offensive Zone, or into any Match Load Zone. Head Referees may provide more specific direction at their discretion, depending on the context of the Match and the circumstances that led to the excess Possession.

Significant Q&As

- 1531 - [Triballs held between a wall and the Robot may be considered Possessed](#)
- 1543 - [Robots do not transitively Possess Triballs through other Robots](#)
- 1610 - [Visual examples of Plowing vs Possession](#)
- 1622 - [Vertical concavities are more likely to result in Plowing than Possession](#)
- 1667 - [Extra Triballs should be removed in a location that doesn't affect the Score](#)
- 1684 - [Robots can work together to plow Triballs](#)
- 1840 - [Momentarily possessing a 2nd Triball is not a Violation](#)

<SG8> Stay out of your opponent's Goal unless they are Double-Zoned. During the time when an *Alliance* meets the definition of *Double-Zoning*, opposing *Robots* are permitted to "break the plane" of the *Double-Zoning Alliance's Goal*, such as to remove *Triballs*.

- a. This allowance ends once the *Alliance* is no longer *Double-Zoning* (i.e., when one or both of the *Robots* has returned to the other side of the field or contacted the *Long Barrier*).
- b. Entering an opponent's *Goal* at any other time is prohibited. This includes staying inside of an opponent's *Goal* after they end their *Double-Zone* status.
- c. This rule applies to both intentional and unintentional interactions. *Teams* are responsible for the actions of their own *Robots*.
- d. This rule only applies during the *Driver Controlled Period*. Entering an opponent's *Goal* is not permitted at any time during the *Autonomous Period*.
- e. If an *Alliance* has only one *Robot* present, then that *Alliance* can never meet the definition of *Double-Zoning*, and therefore its *Goal* is never open for opponent interactions.

Violation Notes: Attempting to remove Triballs from an opponent's Goal is an intentional and inherently defensive action. Therefore, <G14> will apply to these interactions, and the offensive Alliance will always receive the "benefit of the doubt" in the case of any close judgment calls between opposing Robots.

Significant Q&As:

- 1554 - [Robot is in Violation if Double-Zoning ends while in the opponent's Goal](#)
- 1570 - [A Robot that is not in contact with the field tiles cannot be Double-Zoned](#)
- 1594 - [A Robot touching both Offensive Zones counts toward Double-Zoning](#)
- 1690 - [Contacting the outside of the Goal risks a judgment-based Violation call](#)
- 1830 - [Triballs descored during an SG8 Violation may be a DQ if Match Affecting](#)

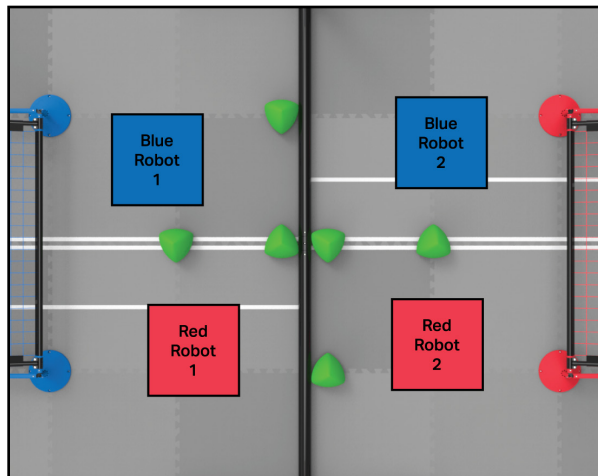

Figure 29: One Robot from each Alliance in their respective Offensive Zones; Triballs in Goals are safe.

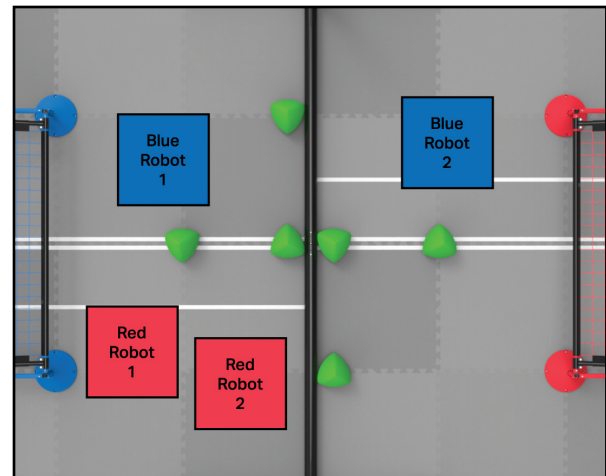

Figure 30: Both Red Robots are in the Blue Offensive Zone; Red Goal is open for de-scoring by a Blue Robot.

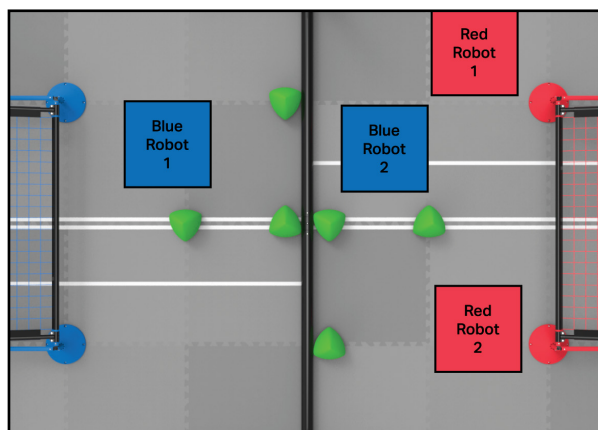

Figure 31: Both Red Robots are in the Red Offensive Zone; Red Goal is open for de-scoring by a Blue Robot.

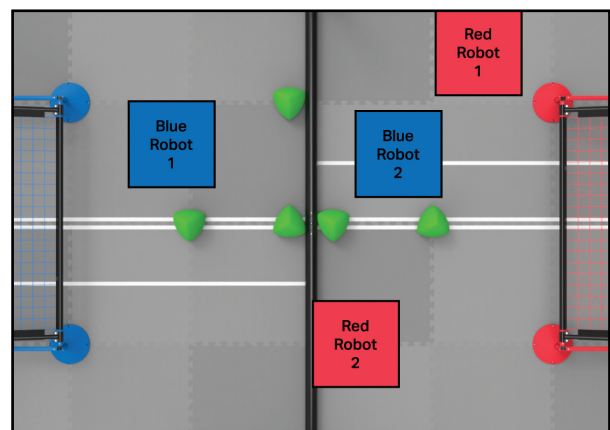

Figure 32: A Red Robot is contacting the Long Barrier; the Red Alliance is NOT Double-Zoning, therefore Triballs in Goals are safe.

<SG9> Stay in your starting Zone during Autonomous. During the *Autonomous Period*, Robots may not contact foam tiles, *Triballs*, or Field Elements that are entirely on the opposing *Alliance's* side of the *Neutral Zone*, or entirely in the opposite *Offensive Zone* from which they began the *Match*.

- a. <G17> does not apply to this rule, unless egregiously exploited for strategic gain. It is expected that *Triballs* which are launched as part of normal Autonomous gameplay may contact foam tiles on the opponent's side of the field.

Violation Notes:

- *Intentional, strategic, or egregious violations, such as intentional contact with an opposing Robot while contacting the foam tiles past the Neutral Zone, will be considered Major Violations.*
- *Intentionally using a Triball to interfere with the Match Load Zone that is used for an opponent's Autonomous Win Point may be considered an example of exploiting <G17> for strategic gain. If the opponent has already successfully retrieved their Triball when the Violation occurs, then this will be considered a Minor Violation of <SG9>, and the Autonomous Win Point is not affected (per <SC7>). If the opponent has not retrieved their Triball, then this will be considered a Major Violation.*

Significant Q&As:

- 1963 - [Robots can contact Triballs that have legally changed Zones](#)

<SG10> Enter the Neutral Zone during Autonomous at your own risk. Any *Robot* who engages with the *Neutral Zone* during the *Autonomous Period* should be aware that opponent *Robots* may also choose to do the same. Per <G11> and <G12>, *Teams* are responsible for the actions of their *Robots* at all times.

- a. If opposing *Robots* contact one another while both engaging with the *Neutral Zone*, and a possible <G13> violation results (i.e., damage, *Entanglement*, or tipping over), then a judgment call will be made by the *Head Referee* within the context of <G13> and <G14> just as it would if the interaction had occurred during the *Driver Controlled Period*.
- b. In the context of <G14>, the *Zones* will always determine "offensive"/"defensive" roles during the *Autonomous Period*. For example, in Figure 33, the *Robots* are in the *Blue Offensive Zone*. Therefore, if an interaction occurred in the *Neutral Zone* that required a *Head Referee* judgment call, then *Robot B1* would receive the "benefit of the doubt."

The *Neutral Zone* is intended to be a zone that *Robots* from both *Alliances* can utilize during the *Autonomous Period*. This will inevitably result in *Robot-on-Robot* interactions, both incidental and intentional. The overarching intent of <SG10> is for the vast majority of these interactions to result in no rule *Violations* and / or penalties for either *Alliance*, just as no rules *Violations* occur in 99% of *Driver Controlled Period* interactions.

Teams are responsible for the actions of their *Robots* at all times. A *Robot* with a small wheel base, who tips over every time they enter the *Neutral Zone* and contacts an opponent, should not attempt to claim a <G13> violation on their opponent.

Clause "b" of <SG10> is intended to provide a "benefit of the doubt" tiebreaker for interactions which require a *Head Referee* judgment call beyond clause "a". If the interaction does not require a judgment call, it is not intended to be an automatic "get out of jail free" card. This could refer to interactions in which one *Alliance* is clearly at fault, as well as interactions which would clearly be a "no-call" if they had occurred during the *Driver Controlled Period*. Reckless or unsafe strategies aimed solely at the destruction, damage, tipping over, *Entanglement*, *Trapping*, or forcing of an opponent into a penalty are still prohibited in the VEX Robotics Competition.

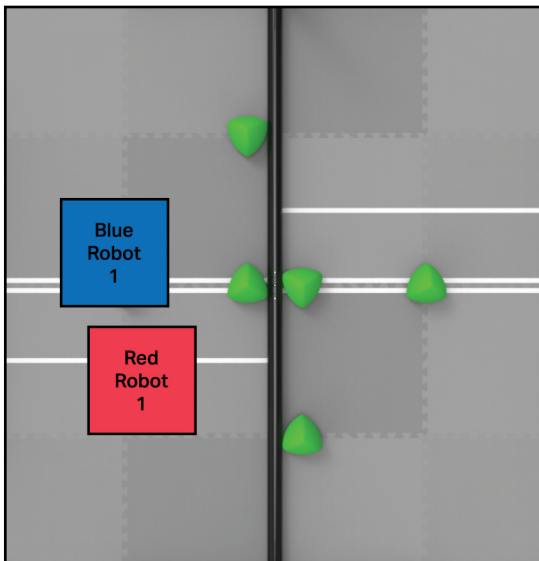

Figure 33: Two Robots legally interacting within the Neutral Zone.

<SG11> **Elevation is protected.** During the last 30 seconds of the *Match*, Robots may not contact the following:

- The opposing *Alliance's Elevation Bars*
- Opponent *Robots* who are contacting their *Elevation Bars*
- Opponent *Robots* who meet the definition of *Elevated*

During the last 15 seconds of the *Match*, Robots may not contact:

- The Short *Barriers* adjacent to the opposing *Alliance's Elevation Bars*.

Violation Notes:

- Regarding points "a" and "d": If no opponent Robots are in the process of *Elevating*, then most incidental or momentary contact is unlikely to be *Match Affecting*, and should only be considered a *Minor Violation*.
- If an egregious *Violation* results in opponent Robot damage, or otherwise severely impedes an opponent's *Elevation*, then it should be assumed that the *Violation* was *Match Affecting* if the opposing *Alliance* loses the *Match* by 20 points or less.

The intent of this rule is to prevent potentially damaging defensive interactions with *Robots* who are in the process of *Elevating*. Indirect contact may also be considered a *Minor* or *Major Violation* of <G1>, <G13>, or <SG11> at the *Head Referee's* discretion. This could include actions such as:

- Repeatedly hitting the field perimeter wall that the opponent's *Elevation Bar* is connected to
- Repeatedly hitting the *Barrier* adjacent to the opponent's *Elevation Bar*
- Launching *Triballs* at an *Elevated Robot*

Significant Q&As:

- 1551 - [Factors to help decide whether a Violation is Major or Minor](#)
- 1748 - [An offended Robot that elevates probably wasn't severely impeded; highest possible Elevation Tier is equivalent to the highest Elevated Robot](#)
- 1960 - [Contact with detached part from another Robot might not negate Elevation](#)

Section 3

The Robot

Overview

This section provides rules and requirements for the design and construction of your *Robot*. A VEX Robotics Competition *Robot* is a remotely operated and/or autonomous vehicle designed and built by a registered VEX Robotics Competition *Team* to perform specific tasks.

There are specific rules and limitations that apply to the design and construction of your *Robot*. Please ensure that you are familiar with these *Robot* rules before beginning your *Robot* design. These “inspection rules” are verified prior to the beginning of each event, in a formal *Robot* Inspection.

Inspection Rules are “pass/fail”; there are no Major or *Minor Violations*, only *Violations*. The penalty for all *Violations* is the same, as outlined in <R3d> and <R27>.

Most of these rules are “hard limits,” such as the maximum number of motors permitted. However, some are “at inspector discretion,” such as determining a mechanism’s potential safety risk. At many events, the lead inspector and the *Head Referee* are the same person; if they are not, then the volunteer inspector should confirm any questionable judgment calls with the *Head Referee*. The *Head Referee* has final authority regarding all *Robot* rules, since it is ultimately their decision whether a *Robot* takes the field for a *Match* after inspection has concluded (per <R3d> and <R3e>).

Inspection Rules

<R1> One Robot per Team. Only one (1) *Robot* will be allowed to compete per *Team* at a given event in the VEX Robotics Competition. Though it is expected that *Teams* will make changes to their *Robot* at the competition, a *Team* is limited to only one (1) *Robot* at a given event. A VEX *Robot*, for the purposes of the VEX Robotics Competition, has the following subsystems:

- Subsystem 1: Mobile robotic base including wheels, tracks, legs, or any other mechanism that allows the *Robot* to navigate the majority of the flat playing field surface. For a stationary *Robot*, the robotic base without wheels would be considered Subsystem 1.
- Subsystem 2: Power and control system that includes a legal VEX battery, a legal VEX control system, and associated motors for the mobile robotic base.
- Subsystem 3: Additional mechanisms (and associated motors) that allow manipulation of *Triballs*, Field Elements, or navigation of field obstacles.

Given the above definitions, a minimum *Robot* for use in any VEX Robotics Competition event (including Skills Challenges) must consist of subsystems 1 and 2 above. Thus, if you are swapping out an entire subsystem 1 or 2, you have now created a second *Robot* and have *Violated* this rule.

- a. *Teams* may not compete with one *Robot* while a second is being modified or assembled at a competition.

- b. *Teams* may not have an assembled second *Robot* on-hand at a competition that is used to repair or swap parts with the first *Robot*.
- c. *Teams* may not switch back and forth between multiple *Robots* during a competition. This includes using different *Robots* for *Skills Challenges*, *Qualification Matches* and/or *Elimination Matches*.
- d. Multiple *Teams* may not use the same *Robot*. Once a *Robot* has competed under a given *Team* number at an event, it is “their” *Robot*; no other *Teams* may compete with it for the duration of the competition season.

The intent of <R1a>, <R1b>, and <R1c> is to ensure an unambiguous level playing field for all *Teams*. *Teams* are welcome (and encouraged) to improve or modify their *Robots* between events, or to collaborate with other *Teams* to develop the best possible game solution.

However, a *Team* who brings and/or competes with two separate *Robots* at the same tournament has diminished the efforts of a *Team* who spent extra design time making sure that their one *Robot* can accomplish all of the game’s tasks. A multi-*Team* organization that shares a single *Robot* has diminished the efforts of a multi-*Team* organization who puts in the time, effort, and resources to undergo separate individual design processes and develop their own *Robots*.

To help determine if a *Robot* is a “separate *Robot*” or not, use the subsystem definitions found in <R1>. Above that, use common sense as referenced in <G3>. If you can place two *Robots* on a table next to each other, and they look like two separate legal/complete *Robots* (i.e., each has the 3 subsystems defined by <R1>), then they are two *Robots*. Trying to decide if changing a screw, a wheel, or a microcontroller constitutes a separate *Robot* is missing the intent and spirit of this rule.

Significant Q&As:

- 1871 - [Team can bring and swap modular subsystem 3s, but all configurations must be inspected](#)

<R2> Robots must represent the Team’s skill level. The *Robot* must be designed, built, and programmed by members of the *Team*. *Adults* are expected to mentor and teach design, building, and Programming Skills to the *Students* on the *Team*, but may not design, build, or program that *Team’s Robot*. See rules <G2> and <G4>.

In VRC, we expect *Adults* to teach fundamental *Robot* principles like linkages, drive-trains, and manipulators, then allow the *Students* to determine which designs to implement and build on their *Robot*.

Similarly, *Adults* are encouraged to teach the *Students* how to code various functions involving applicable sensors and mechanisms, then have the *Students* program the *Robot* from what they have learned.

<R3> Robots must pass inspection. Every *Robot* will be required to pass a full inspection before being cleared to compete. This inspection will ensure that all *Robot* rules and regulations are met. Initial inspections will take place during team registration/practice time. Noncompliance with any *Robot* design or construction rule will result in removal from *Matches* or *Disqualification* of the *Robot* at an event until the *Robot* is brought back into compliance, as described in the following subclauses.

- a. Significant changes to a *Robot*, such as a partial or full swap of Subsystem 3, must be re-inspected before the *Robot* may compete again.
- b. All possible functional *Robot* configurations must be inspected before being used in competition. This especially pertains to modular or swappable mechanisms (per <R1>) and *Match* starting configurations/sizes (per <R4>).
- c. *Teams* may be requested to submit to random spot inspections by *Head Referees*. Refusal to submit will result in *Disqualification*.
 - i. If a *Robot* is determined to be in *Violation* of a *Robot* rule before a *Match* begins, the *Robot* will be removed from the field. A *Drive Team Member* may remain at the field so that the *Team* does not get assessed a "no-show" (per <T5>).
- d. *Robots* which have not passed inspection (i.e., that may be in *Violation* of one or more *Robot* rules) will not be permitted to play in any *Matches* until they have done so. <T5> will apply to any *Matches* that occur until the *Robot* has passed inspection.
- e. If a *Robot* has passed inspection, but is later confirmed to be in *Violation* of a *Robot* rule during or immediately following a *Match* by a *Head Referee*, they will be *Disqualified* from that *Match*. This is the only *Match* that will be affected; any prior *Matches* that have already been completed will not be revisited. <R3d> will apply until the *Violation* is remedied and the *Team* is re-inspected.
- f. All Inspection Rules are to be enforced within the discretion of the *Head Referee* within a given event. *Robot* legality at one event does not automatically imply legality at future events. *Robots* which rely on "edge-case" interpretations of subjective rules, such as whether a decoration is "non-functional" or not, should expect additional scrutiny during inspection.

<R4> Robots must fit within an 18" x 18" x 18" volume.

- a. Compliance with this rule must be checked using the official VEX Robotics On-Field Robot Expansion Sizing Tool: <https://www.vexrobotics.com/276-5942.html>.
- b. Any restraints used to maintain starting size (i.e., zip ties, rubber bands, etc.) must remain attached to the *Robot* for the duration of the *Match*, per <G6>.
- c. For the purposes of this rule, it can be assumed that *Robots* will be inspected and begin each *Match* on a flat standard foam field tile.

The official sizing tool is intentionally manufactured with a slightly oversized tolerance. Therefore, any contact with the sizing tool (i.e., a "paper test") while being measured should be considered a clear indication that a *Robot* is outside of the permitted size. This tolerance also provides a slight "leeway" for minor protrusions, such as screw heads or zip ties.

Other tools, such as custom sizing boxes or the legacy non-expanding VEX Sizing Tool (276-2086), may be used for informal checks. However, in the event of a conflict or “close call,” a check with the official On-Field Robot Expansion Sizing Tool takes precedence.

Although it is not required by <R4>, events may also choose to check that any possible *Robot* expansion satisfies the requirements of <SG2> during inspection. The intent of this check is to help *Teams* identify any potential *Violation* risks before their *Matches*.

<R5> Robots must be safe. The following types of mechanisms and components are NOT allowed:

- a. Those that could potentially damage Field Elements or *Triballs*.
- b. Those that could potentially damage other competing *Robots*.
- c. Those that pose an unnecessary risk of *Entanglement* with other *Robots* or a net.
- d. Those that could pose a potential safety hazard to *Drive Team Members*, event staff, or other humans.

<R6> Robots are built from the VEX V5 system. *Robots* may be built ONLY using official VEX V5 components, unless otherwise specifically noted within these rules. *Teams* are responsible for providing documentation proving a part’s legality in the event of a question. Examples of documentation include receipts, part numbers, official VEX websites, or other printed evidence.

- a. Products from the VEXpro, VEX EXP, VEX IQ, VEX GO, VEX 123, or VEX Robotics by HEXBUG* product lines cannot be used for *Robot* construction, unless specifically allowed by a clause of <R7> or “cross-listed” as part of the VEX V5 Product lines. For example, Flex Wheels and Versa-Hubs are VEXpro components that can be found on the VEX “Flex Wheels” page, and are thus legal: <https://www.vexrobotics.com/vrc-flex-wheels.html>.

* The HEXBUG brand is a registered trademark belonging to Spin Master Corp

- b. The following electronics from the VEX Cortex control system are not permitted.

SKU	Description
276-2192	VEXnet Joystick
276-1891	VEXnet Partner Joystick
276-2194	VEX ARM® Cortex-based Microcontroller
276-2245 / 276-3245	VEXnet Key 1.0 / 2.0
276-2177	2-Wire Motor 393
276-2162	3-Wire Servo
276-2210	VEX Flashlight
276-2193	Motor Controller 29

- c. The following electronics from the VEX Cortex control system are permitted.

SKU	Description
276-2174 / 276-4859	Limit Switch V1 / V2
276-2159	Bumper Switch
276-2156	Optical Shaft Encoder
276-2216	Potentiometer
276-2155	Ultrasonic Range Finder
276-2176	LED Indicator
276-2333	Yaw Rate Gyroscope
276-2332	Analog Accelerometer V1.0
276-2154	Line Tracker
276-1380	Jumper
276-2158	Light Sensor

- d. Components that are unique to the V5 Workcell product line are not permitted. This includes the following.

SKU	Description
276-7151	Robot Arm Metal
276-7152	Robot Brain Mount
276-7153	Input Output Conveyor
276-7720	Disc Feeder
276-7047	V5 Electromagnet

- e. VEX IQ pins are permitted.
- f. Components obtained from the V5 beta program, including V5 beta firmware, are not legal for competition use.
- i. All V5 beta hardware can be identified by its lighter gray pre-production color. Robot Brains, Robot Batteries, Controllers, and Vision Sensors from the V5 beta have a "BETA TEST" stamp on them. Smart Motors and Radios do not have this stamp, but can still be identified by color.
- g. Components from the VEXplorer kit that are not found in modern VEX V5 kits are not permitted. These include (but may not be limited to) electronics, wheels, non-standard gears, and plastic connectors.
- h. Official VEX products are ONLY available from VEX Robotics. All official products are listed on www.vexrobotics.com.
- i. Third-party microSD card for in-*Match* file storage, as supported by the VEX API.

Using VEX apparel, competition support materials, packaging, or other non-*Robot* products on a VEX Robotics Competition *Robot* goes against the spirit of this rule and is not permitted.

<R7> Certain non-VEX components are allowed. Robots are allowed the following additional “non-VEX” components:

- a. Any material strictly used as a color filter or a color marker for a legal sensor, such as the VEX Light Sensor or the VEX V5 Vision Sensor.
- b. Any non-aerosol-based grease or lubricating compound, when used in extreme moderation on surfaces and locations that do NOT contact the playing field walls, foam field surface, *Triballs*, or other *Robots*. Grease or lubricant applied directly to V5 Smart Motors or Smart Motor cartridges is prohibited.
- c. Anti-static compound, when used in extreme moderation (i.e., such that it does not leave residue on Field Elements, *Triballs*, or other *Robots*).
- d. Hot glue when used to secure cable connections.
- e. An unlimited amount of rope / string, no thicker than 1/4” (6.35mm).
- f. Commercially available items used solely for bundling or wrapping of 2-wire, 3-wire, 4-wire, or V5 Smart Cables, and/or pneumatic tubing are allowed. These items must solely be used for the purposes of cable/tubing protection, organization, or management. This includes but is not limited to electrical tape, cable carrier, cable track, etc. It is up to inspectors to determine whether a component is serving a function beyond protecting and managing cables and tubing.
- g. Non-functional 3D printed license plates, per <R8> and <R9>, are permitted. This includes any supporting structures whose sole purpose is to hold, mount, or display an official license plate.
- h. Rubber bands that are identical in length and thickness to those included in the VEX V5 product line (#32, #64 and 117B).
- i. Pneumatic components with identical SMC manufacturer part numbers to those listed on the VEX website. For more detail regarding legal pneumatic components, see the Legal VEX Pneumatics Summary document:
<https://kb.vex.com/hc/en-us/articles/17984679227156-Legal-Pneumatics-for-Use-in-the-VEX-Robotics-Competition-VRC->.
- j. Zip ties that are identical in length and thickness to those included in the VEX V5 product line (4” or 11” long).
- k. A Micro SD card installed in the V5 Robot Brain.

See this [REC Library article](#) for more information.

<R8> Decorations are allowed. Teams may add non-functional decorations, provided that they do not affect *Robot* performance in any significant way or affect the outcome of the *Match*. These decorations must be in the spirit of the competition. Inspectors will have final say in what is considered “non-functional.” Unless otherwise specified below, non-functional decorations are governed by all standard *Robot* rules.

To be considered “non-functional,” any guards, decals, or other decorations must be backed by legal materials that provide the same functionality. For example, if a *Robot* has a giant decal that prevents *Triballs* from falling out of the *Robot*, the decal must be backed by VEX material that would also prevent the *Triballs* from falling out. A simple way to check this is to determine if removing the decoration would impact the performance of the *Robot* in any way.

- a. Anodizing and painting of parts is considered a legal nonfunctional decoration.
- b. Small cameras are permitted as non-functional decorations, provided that any transmitting functions or wireless communications are disabled. Unusually large cameras being used as ballast are not permitted.
- c. VEX electronics may not be used as non-functional decorations.
- d. Decorations that visually mimic Field Elements, or could otherwise interfere with an opponent’s Vision Sensor, are considered functional and are not permitted. The Inspector and *Head Referee* will make the final decision on whether a given decoration or mechanism violates this rule.
- e. Internal power sources (e.g., for a small blinking light) are permitted, provided that no other rules are violated and this source only provides power to the non-functional decoration (i.e., does not directly or indirectly influence any functional portions of the *Robot*).
- f. Decorations which provide feedback to the *Robot* (e.g., by influencing legal sensors) would be considered “functional,” and are not permitted.
- g. Decorations which provide visual feedback to *Drive Team Members* (e.g., decorative lighting) are permitted, provided that they do not violate any other rules and serve no other function (e.g., structural support).

<R9> Officially registered Team numbers must be displayed on Robot License Plates. To participate in an official VEX Robotics Competition event, a *Team* must first register on robotevents.com and receive a VRC Team number. This *Team* number must be displayed on a minimum of two (2) opposing sides of the *Robot* using *License Plates*. *Teams* may choose to use the official VRC License Plate Kit, or may create their own.

- a. *Robots* must use plates that match their *Alliance* color for each *Match* (i.e., red *Alliance Robots* must have their red plates on for the *Match*). It must be abundantly clear which color *Alliance* the *Robot* belongs to.
 - i. If both colors of *License Plates* are mounted on a *Robot*, then the incorrect color must be covered, taped over, or otherwise obscured. Since *License Plates* are considered non-functional decorations, this is a legal non-functional use of tape.
- b. *License Plates* are considered non-functional decorations (per <R8>), and must fulfill all relevant *Robot* rules (e.g., they must fit within the 18” cube, cannot functionally change the stability or rigidity of the *Robot*, cause *Entanglement*, etc.)
- c. *Team* numbers must be in white font, and clearly legible.
- d. *License Plates* must be at least 2.48 inches (63.2mm) tall and 4.48 inches (114mm) wide, i.e., at least the height/width dimensions of the plates in the VRC License Plate Kit.

The intent of this rule is to make it immediately apparent to *Head Referees* which *Alliance* and which *Team* each *Robot* belongs to, at all times. Being able to “see through” a *Robot* arm to the wrong color *License Plate* on the opposite side of the *Robot* could cause confusion, and would be considered a violation of <R9a>.

It will be at the full discretion of the *Head Referee* and inspector at a given event to determine whether a given custom *License Plate* satisfies the criteria listed in <R9>.

Teams wishing to utilize custom plates should be prepared for the possibility of this judgment, and ensure that they are prepared to replace any custom parts with official VEX *License Plates* if requested. Not bringing official replacement plates to an event will not be an acceptable reason for overlooking a violation of one or more points in <R9>.

If a *Robot* must be removed from the Field based on this rule, <R3ci> applies and the *Team* should not be issued a “no-show.”



Figure 34: An example of a License Plate made from the VRC License Plate Kit



Figure 35: An example of a legal custom License Plate

<R10> **Let go of Triballs after the Match.** Robots must be designed to permit easy removal of *Triballs* from any mechanism without requiring the *Robot* to have power after a *Match*.

<R11> **Robots have one microcontroller.** Robots must ONLY use one (1) VEX V5 Robot Brain (276-4810). Any other microcontrollers or processing devices are not allowed, even as non-functional decorations.

This includes microcontrollers that are part of other VEX product lines, such as VEX Cortex, VEX EXP, VEXpro, VEX RCR, VEX IQ, VEX GO, or VEX Robotics by HEXBUG. This also includes devices that are unrelated to VEX, such as Raspberry Pi or Arduino devices.

<R12> **Motors are limited.** Robots may use any combination of VEX V5 Smart Motors (11W) (276-4840) and EXP Smart Motors (5.5W) (276-4842), within the following criteria:

- a. The combined power of all motors (11W & 5.5W) must not exceed 88W. This limit applies to all motors on the *Robot*, even those which are not plugged in.
- b. V5 Smart Motors, and EXP Smart Motors connected to Smart Ports, are the only motors that may be used with a V5 Robot Brain. The 3-wire ports may not be used to control motors of any kind.

Examples of legal motor combinations:

Example	A	B	C	D	E
Qty of 11W Motors:	8	7	6	5	0
Qty of 5.5W Motors:	0	2	4	6	16

<R13> Electrical power comes from VEX batteries only. Robots may use one (1) V5 Robot Battery (276-4811) to power the V5 Robot Brain.

- a. No other sources of electrical power are permitted, unless used as part of a non-functional decoration per <R8e>.
- b. There are no legal power expanders for the V5 Robot Battery.
- c. V5 Robot Batteries may only be charged by a V5 Robot Battery Charger (276-4812 or 276-4841).
- d. V5 Wireless Controllers may only be powered by their internal rechargeable battery.
 - i. *Teams* are permitted to have an external power source (such as a rechargeable battery pack) plugged into their V5 Controller during a *Match*, provided that this power source is connected safely and does not violate any other rules, such as <G10> or <R14>.
 - ii. Some events may choose to provide field power for V5 Wireless Controllers. If this is provided for all *Teams* at the event, then this is a legal power source for the wireless remotes.

<R14> No modifications to electronic or pneumatic components are allowed. Motors (including the internal PTC or V5 / EXP Smart Motor firmware), microcontrollers (including V5 Robot Brain firmware), cables, sensors, controllers, battery packs, reservoirs, solenoids, pneumatic cylinders, and any other electrical or pneumatics component of the VEX platform may NOT be altered from their original state in ANY way. Clauses ci-civ also apply to EXP Smart Motors (5.5W).

- a. External wires on VEX 2-wire or 3-wire electrical components may be repaired by soldering or using twist/crimp connectors, electrical tape, or shrink tubing such that the original functionality and length are not modified in any way.
 - i. Wire used in repairs must be identical to VEX wire.
 - ii. *Teams* make these repairs at their own risk; incorrect wiring may have undesired results.
- b. *Teams* must use the latest official VEXos firmware updates, found at <https://link.vex.com/firmware>. Custom firmware modifications are not permitted.
- c. *Teams* may make the following modifications to the V5 / EXP Smart Motor user-serviceable features. **This list is all-inclusive**; no other modifications are permitted. Where applicable, the components listed below (in the specific applications listed below) are permissible exceptions to <R20>.
 - i. Replacing the gear cartridge with other official cartridges.
 - ii. Removing or replacing the screws from the V5 Smart Motor Cap (276-6780).

- iii. Removing or replacing the threaded mounting inserts (276-6781).
- iv. Aesthetic/non-functional labeling (e.g., markers, stickers, paint, etc.).
- d. V5 Smart Motors (11W) **must** use an official VEX V5 gear cartridge. For the purposes of this rule, the gear cartridges found within the V5 Smart Motor are considered "part of the motor." Therefore, any physical or functional modifications to official gear cartridges is not permitted.
- e. For the purposes of this rule, the V5 Smart Motor Cap is not considered "part of the motor." Therefore, <R15> applies.

<R15> Most modifications to non-electrical components are allowed. Physical modifications, such as bending or cutting, of legal metal structure or plastic components are permitted.

- a. Internal or external mechanical repairs of VEX Limit and Bumper switches are permitted.
 - i. Modifying the metal arm on the Limit Switch is permitted.
 - ii. Using components from these devices in other applications is prohibited.
- b. Metallurgical modifications that change fundamental material properties, such as heat treating or melting, are not permitted.
- c. Pneumatic tubing may be cut to desired lengths.
- d. Fusing/melting the end of legal nylon rope/string (see <R7e>) to prevent fraying is permitted.
- e. Welding, soldering, brazing, gluing, or attaching parts to each other in any way that is not provided within the VEX platform is not permitted.
- f. Mechanical fasteners may be secured using Loctite or a similar thread-locking product. This may **ONLY** be used for securing hardware, such as screws and nuts.

<R16> Robots use VEXnet. Robots must **ONLY** utilize the VEXnet system for all wireless *Robot* communication.

- a. Electronics from the Cortex, VEX EXP, VEXpro, VEX RCR, VEXplorer, VEX IQ, VEX GO, or VEX Robotics by HEXBUG product line are prohibited unless otherwise noted in <R6c>.
- b. V5 Controllers may only be used in conjunction with a V5 Robot Brain.
- c. *Teams* are permitted to use the Bluetooth® capabilities of the V5 Robot Brain and/or V5 Controller in *Team* pits or outside of *Matches*. However, VEXnet must be used for wireless communication during *Matches*.
- d. *Teams* are permitted to use the Wi-Fi capabilities of the Vision Sensor in *Team* pits or outside of *Matches*. However, the Vision Sensor must have its wireless transmitting functionality disabled during *Matches*.

<R17> Give the radio some space. The V5 Radio must be mounted such that no metal surrounds the radio symbol on the V5 Radio.

It is fine to loosely encapsulate the V5 Radio within *Robot* structure. The intent of this rule is to minimize radio connection issues by minimizing obstructions between VEXnet devices. Burying a radio deep within a *Robot* may result in *Robot* communication issues.

<R18> A limited amount of custom plastic is allowed. *Robots* may use custom-made parts cut from certain types of non-shattering plastic. It must be possible to have cut all of the plastic parts on the *Robot* from a single 12" x 24" sheet, up to 0.070" thick.

- a. The intent of the area/thickness constraints is to limit the number of custom plastic parts used in *Robot* construction, not to define an absolute volume. For example, using a sheet which is 0.035" thick does not permit two 12" x 24" sheets' worth of parts.
- b. Plastic parts do not have to be literally cut from the same original 12" x 24" sheet. However, all individual parts must be able to "nest" or rearrange into a 12" x 24" area.
 - i. A collection of parts which theoretically have a total surface area of 288 in², but cannot be nested onto a single 12" x 24" sheet, would not be legal. See Figure 36.
- c. Plastic may be mechanically altered by cutting, drilling, bending, etc. It cannot be chemically treated, melted, or cast. Heating polycarbonate to aid in bending is acceptable.
- d. Legal plastic types include polycarbonate (Lexan), acetal monopolymer (Delrin), acetal copolymer (Acetron GP), POM (acetal), ABS, PEEK, PET, HDPE, LDPE, Nylon (all grades), Polypropylene, and FEP.
- e. Shattering plastic, such as PMMA (also called Plexiglass, Acrylic, or Perspex), is prohibited.
- f. Plastic sheets sold by VEX are considered "plastic" in the context of this rule, and are subject to the same limitations as "off-the-shelf" plastic sheets. Examples include the 276-8340 PET sheets, and the 217-6626 / 217-6627 polycarbonate sheets.
- g. This rule does not apply to 3D printed plastic parts. 3D printed parts are not permitted in the VEX Robotics Competition, except as non-functional decorations (per <R8>) or as custom *License Plates* (per <R9>).

Note: The phrase "as cut from a single 12" x 24" sheet" is intended to mean that all individual plastic pieces must be able to theoretically "nest" or rearrange into a 12" x 24" area. The plastic pieces do not have to be cut from the same original 12" x 24" sheet. Teams are encouraged to "map" plastic use on a 12"x24" sheet of paper for reference at tournament inspection.

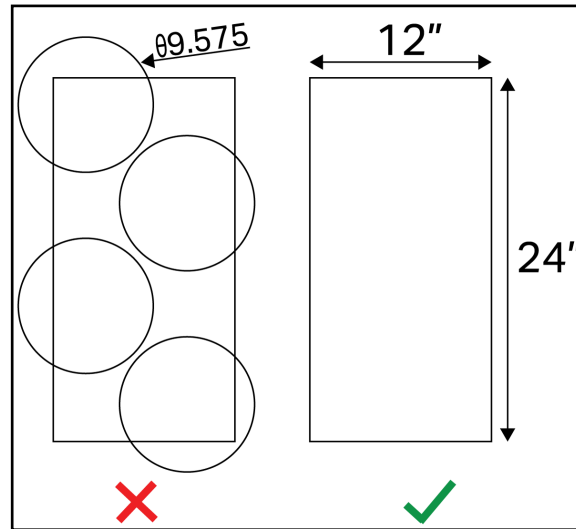

Figure 36: Custom plastic parts must fit within a single 12" x 24" sheet of plastic.

<R19> A limited amount of tape is allowed. Robots may use a small amount of tape for the following purposes:

- To secure any connection between the ends of two (2) VEX cables.
- To label wires and motors.
- To cover the backs of license plates (i.e., hiding the "wrong color").
- To prevent leaks on the threaded portions of pneumatic fittings. This is the only acceptable use of Teflon tape.
- In any other application that would be considered a "non-functional decoration" per <R8>.

<R20> Certain non-VEX fasteners are allowed. Robots may use the following commercially available hardware:

- #4, #6, #8, M3, M3.5, or M4 screws up to 2.5" (63.5mm) long.
- Shoulder screws cannot have a shoulder length over 0.20" or a diameter over 0.176".
- Any commercially available nut, washer, standoff, and/or non-threaded spacer up to 2.5" (63.5mm) long which fits these screws.

The intent of the rule is to allow *Teams* to purchase their own commodity hardware without introducing additional functionality not found in standard VEX equipment. It is up to inspectors to determine whether the non-VEX hardware has introduced additional functionality or not.

For the purposes of this rule, weight savings is not considered additional functionality.

If a key component of a *Robot's* design relies upon convincing an inspector that a specialized component is "technically a screw," it is probably outside of the spirit and intent of this rule.

All specific dimensions listed in this rule are intended to be 'nominal' references to hardware sizes found within the VEX V5 product line and/or their metric equivalents.

<R21> New VEX parts are legal. Additional VEX components released during the competition season on www.vexrobotics.com are considered legal for use unless otherwise noted.

Some "new" components may have certain restrictions placed on them upon their release. These restrictions will be documented in the official Q&A, in a Game Manual Update, or on their respective product web pages.

<R22> Pneumatics are limited. A *Robot's* pneumatic subsystem must satisfy the following criteria:

- a. *Teams* may use a maximum of two (2) legal VEX pneumatic air reservoirs on a *Robot*. The Air Tank 200mL (included in the 276-8750 V5 Pneumatics Kit) and the legacy (pre-2023) reservoir are both considered legal reservoirs.
- b. Pneumatic devices may be charged to a maximum of 100 psi.
- c. The compressed air contained inside a pneumatic subsystem can only be used to actuate legal pneumatic devices (e.g., cylinders).

Note: From a rules perspective, parts found in the V5 Pneumatics Kit (276-8750) and legacy (pre-2023) pneumatic parts may be used interchangeably. A Legal Pneumatics summary can be found [in the VEX Library](#), which includes additional pneumatics information.

The intent of <R22a> and <R22b> is to limit *Robots* to the air pressure stored in two reservoir tanks, as well as the normal working air pressure contained in their pneumatic cylinders and tubing on the *Robot*. *Teams* may not use other elements for the purposes of storing or generating air pressure.

Using cylinders or additional pneumatic tubing solely for additional storage is in *Violation* of the spirit of this rule. Similarly, using pneumatic cylinders and/or tubing without any air reservoirs is also in *Violation* of the spirit of this rule.

The intent of <R22c> is to ensure that pneumatics are being used safely. Pressurized systems, such as a *Robot's* pneumatic subsystem, have the potential to be dangerous if used incorrectly. This rule ensures the safety of participants, and prevents potentially unsafe uses in the future.

Another way of thinking of <R22c> is that pneumatics should only be used with pneumatics. *Teams* should not use compressed air as a means of actuating non-pneumatic devices such as screws, nuts, etc. For example, pulling a pin with a pneumatic cylinder is okay, but using air to actuate the pin itself is not.

<R23> One or two Controllers per Robot. No more than two (2) VEX V5 Controllers may control a single *Robot*.

- a. No physical or electrical modification of these Controllers are allowed under any circumstances.
 - i. Attachments which assist the *Drive Team Member* in holding or manipulating buttons/ joysticks on the V5 Controller are permitted, provided that they do not involve direct physical or electrical modification of the Controller itself.
- b. No other methods of controlling the *Robot* (light, sound, etc.) are permissible.
 - i. Using sensor feedback to augment driver control (such as motor encoders or the Vision Sensor) is permitted.

<R24> Custom V5 Smart Cables are allowed. *Teams* who create custom cables acknowledge that incorrect wiring may have undesired results.

- a. Official V5 Smart Cable Stock must be used.
- b. Use of non-VEX 4P4C connectors and 4P4C crimping tools is permissible.
- c. V5 Smart Cables may only be used for connecting legal electronic devices to the V5 Robot Brain.

<R25> Keep the power button accessible. The on/off button on the V5 Robot Brain must be accessible without moving or lifting the *Robot*. All screens and/or lights must also be easily visible by competition personnel to assist in diagnosing *Robot* problems.

<R26> Use a "Competition Template" for programming. The *Robot* must be programmed to follow control directions provided by the VEXnet Field Controllers or Smart Field Control system.

During the *Autonomous Period*, *Drive Team Members* will not be allowed to use their V5 Controllers. As such, *Teams* are responsible for programming their *Robot* with custom software if they want to perform in the *Autonomous Period*. *Robots* must be programmed to follow control directions provided by the field controls (i.e., ignore wireless input during the *Autonomous Period*, disable at the end of the *Driver Controlled Period*, etc.).

Teams must use a provided "competition template" or functional equivalent to accomplish this. This will be tested in inspection, where *Robots* will be required to pass a functional "enable/disable" test. For more information on this, *Teams* should consult the help guides produced by the developers of their chosen programming software.

<R27> There is a difference between accidentally and willfully violating a Robot rule. Any violation of *Robot* rules, accidental or intentional, will result in a *Team* being unable to play until they pass inspection (per <R3d>).

However, *Teams* who intentionally and/or knowingly circumvent or violate rules to gain an advantage over their fellow competitors are in violation of the spirit and ethos of the competition. Any *Violation* of this sort may be considered a violation of <G1> and/or the REC Foundation Code of Conduct.

Section 4

The Tournament

Overview

VEX Robotics Competition *Matches* are played in a Head-to-Head tournament format. Head-to-Head Tournaments consist of *Qualification Matches* and *Elimination Matches*. *Qualification Matches* are used to rank *Teams* based on *Win Points* (WP), *Autonomous Points* (AP), and *Strength of Schedule Points* (SP). The top-ranked *Teams* will then form *Alliances* to participate in *Elimination Matches* and determine the tournament champions. For information about the requirements for tournaments that qualify teams to championship events, [visit this article in the REC Library](#).

This section refers primarily to Head-to-Head *Matches*. For other types of *Matches*, see Appendices B & C.

Tournament Definitions

Alliance Captain – One of the *Teams* with the privilege of inviting another available *Team* to form an *Alliance* for the *Elimination Matches*. See <T18>.

Alliance Selection – The process of choosing the permanent *Alliances* for the *Elimination Matches*. *Alliance Selection* proceeds as follows:

1. The highest-ranked *Team* at the end of *Qualification Matches* becomes the first *Alliance Captain*.
2. The *Alliance Captain* invites another *Team* to join their *Alliance*.
3. The invited *Team Representative* either accepts or declines as outlined in <T18>.
4. The next-highest-ranked *Team* becomes the next *Alliance Captain*.
5. *Alliance Captains* continue to select their *Alliances* in this order until all *Alliances* are formed for the *Elimination Matches*.

Autonomous Points (AP) – The second basis of ranking *Teams*. An *Alliance* who wins the *Autonomous Bonus* during a *Qualification Match* earns eight (8) *Autonomous Points*. In the event of a tie, both *Alliances* will receive four (4) *Autonomous Points*.

Autonomous Win Point – One (1) *Win Point* (WP) given to an *Alliance* that completes the tasks described in <SC7>, by the end of the *Autonomous Period*. Both *Alliances* can earn this WP if both *Alliances* accomplish this task.

Bye – An *Elimination Match* in which an *Alliance* automatically advances to the next round of tournament play without competing.

Elimination Bracket – A schedule of *Elimination Matches* for eight (8) to sixteen (16) *Alliances*. See <T19>.

Elimination Match – A *Match* used in the process of determining the champion *Alliance*. *Alliances* of two (2) *Teams* face off according to the *Elimination Bracket*; the winning *Alliance* moves on to the next round.

Event Partner – The volunteer VEX Robotics Competition tournament coordinator who serves as an overall manager for the volunteers, venue, event materials, and all other event considerations. *Event Partners* serve as the official liaison between the REC Foundation, the event volunteers, and event attendees.

Head Referee – A certified impartial volunteer responsible for enforcing the rules in this manual as written. *Head Referees* are the only individuals who may discuss ruling interpretations or scoring questions with *Teams* at an event. Large events (e.g., Signature Events, World Championships, etc.) might include multiple *Head Referees* at the *Event Partner’s* discretion.

Match Schedule – A list of *Matches* that is generated at the start of an event. The *Match Schedule* includes the predetermined, randomly-paired *Alliances* that will be competing in each *Qualification Match*, and the expected start times for these *Matches*. The *Match Schedule* may be subject to change at the *Event Partner’s* discretion.

Qualification Match List KALAHARI CLASSIC INDOOR WATERPARK VEX VRC High School Signature Event - Zambezi						
Match	Field	Time	Red 1	Red 2	Blue 1	Blue 2
Q1	Field 1	Fri 9:00 AM	3547Y	7316G	248E	99999V
Q2	Field 1	Fri 9:06 AM	3145M	26681B	8823G	23017A
Q3	Field 1	Fri 9:12 AM	59759A	45224A	6008B	2011G
Q4	Field 1	Fri 9:18 AM	75476Z	7882F	11124E	169A
Q5	Field 1	Fri 9:24 AM	7882B	9364C	40938A	1375A
Q6	Field 1	Fri 9:30 AM	7316A	98575A	6210Y	6741A
Q7	Field 1	Fri 9:36 AM	97031A	6008Z	6741E	7316X
Q8	Field 1	Fri 9:42 AM	2894B	5430A	1274A	3547A
Q9	Field 1	Fri 9:48 AM	11254X	60883D	23017C	2719J
Q10	Field 1	Fri 9:54 AM	323V	9364E	2011A	81P
Q11	Field 1	Fri 10:00 AM	6842C	2719A	6302U	248C
Q12	Field 1	Fri 10:06 AM	11124W	6403W	9364A	9257C
Q13	Field 1	Fri 10:12 AM	2011C	6008N	244D	44691X
Q14	Field 1	Fri 10:18 AM	60470S	8823C	8823E	11124P
Q15	Field 1	Fri 10:24 AM	7316E	2011E	38141A	40938C

Figure 37: An example of a Qualification Match Schedule

Practice Match – A *Match* used to provide time for *Teams* and volunteers to get acquainted with the official playing field and procedures. *Practice Matches* earn *Teams* zero (0) *Win Points*, *Autonomous Points*, and *Strength of Schedule Points*.

Qualification Match – A *Match* used to determine *Team* rankings for *Alliance Selection*. Each *Qualification Match* consists of two *Alliances* competing to earn *Win Points*, *Autonomous Points*, and *Strength of Schedule Points*.

Scorekeeper Referee – An impartial volunteer responsible for tallying scores at the end of a *Match*. *Scorekeeper Referees* do not make ruling interpretations, and should redirect any *Team* questions regarding rules or scores to a *Head Referee*.

Strength of Schedule Points (SP) – The third basis of ranking *Teams*. *Strength of Schedule Points* are equivalent to the score of the losing *Alliance* in a *Qualification Match*. In the event of a tie, both *Alliances* receive SP's equal to the tie score. If both *Teams* on an *Alliance* are Disqualified, the *Teams* on the not Disqualified *Alliance* will receive their own score as SP's for that *Match*.

Time Out – A single break period no greater than three minutes (3:00) allotted for each *Alliance* during the *Elimination Bracket*. See <T9>.

Win Points (WP) – The first basis of ranking *Teams*. *Teams* will receive zero (0), one (1), two (2), or three (3) *Win Points* for each *Qualification Match*. Unless a *Team* is Disqualified, both *Teams* on an *Alliance* always earn the same number of WP's.

- One (1) WP is awarded for completing the *Autonomous Win Point* task(s).
- Two (2) WP's are awarded for winning a *Qualification Match*.
- One (1) WP is awarded for tying a *Qualification Match*.
- Zero (0) WP's are awarded for losing a *Qualification Match*.

Win Percentage (WP) – Replaces *Win Points* in a league event. *Win Percentage* is calculated by the number of wins divided by the number of *Qualification Matches* the team plays. In cases of a tie, the *Team* is given a 0.5 number of "wins" for that match. The *Autonomous Win Point* is also considered 0.5 "wins," added to the total number of wins.

Tournament Rules

<T1> Head Referees have ultimate and final authority on all gameplay ruling decisions during the competition.

- a. *Scorekeeper Referees* score the *Match*, and may serve as observers or advisers for *Head Referees*, but may not determine any rules or infractions directly.
- b. When issuing a *Major Violation* or *Minor Violation* to a *Team*, *Head Referees* must provide the rule number of the specific rule that has been Violated, and record the *Violation* on the Match Anomaly Log
- c. *Violations* of the REC Foundation Code of Conduct may involve additional escalation beyond a *Head Referee's* initial ruling, including (but not limited to) investigation by an REC Foundation representative. Rules <S1>, <G1>, and <G2> are the only rules for which this escalation may be required.
- d. *Event Partners* may not overrule a *Head Referee's* decision.
- e. Every *Qualification Match* and *Elimination Match* must be watched by a *Head Referee*. *Head Referees* may only watch one *Match* at a time; if multiple *Matches* are happening simultaneously on separate fields, each field must have its own *Head Referee*.

Note from the VEX GDC: The rules contained in this Game Manual are written to be enforced by human *Head Referees*. Many rules have "black-and-white" criteria that can be easily checked. However, some rulings will rely on a judgment call from this human *Head Referee*. In these cases, *Head Referees* will make their calls based on what they and the *Scorekeeper Referees* saw, what guidance is provided by their official support materials (the Game Manual and the Q&A), and most crucially, the context of the *Match* in question.

The VEX Robotics Competition does not have video replay, our fields do not have absolute sensors to count scores, and most events do not have the resources for an extensive review conference between each *Match*.

When an ambiguous rule results in a controversial call, there is a natural instinct to wonder what the "right" ruling "should have been," or what the GDC "would have ruled." This is ultimately an irrelevant question; our answer is that when a rule specifies "*Head Referee's* discretion" (or similar), then the "right" call is the one made by a *Head Referee* in the moment. The VEX GDC designs games, and writes rules, with this expectation (constraint) in mind.

<T2> Head Referees must be qualified. *Head Referees* must have the following qualifications:

- a. Be at least 20 years of age.
- b. Be approved by the *Event Partner*.
- c. Be an REC Foundation Certified VRC *Head Referee* for the current season.

Note: Scorekeeper Referees must be at least 15 years of age, and must be approved by the Event Partner.

Head Referees should demonstrate the following attributes:

- Thorough knowledge of the current game and rules of play
- Effective decision-making skills
- Attention to detail
- Ability to work effectively as a member of a team
- Ability to be confident and assertive when necessary
- Strong communication and diplomacy skills

<T3> The Drive Team is permitted to immediately appeal a Head Referee's ruling. If *Drive Team Members* wish to dispute a score or ruling, they must stay in the *Alliance Station* until the *Head Referee* from the *Match* talks with them. The *Head Referee* may choose to meet with the *Drive Team Members* at another location and/or at a later time so that the *Head Referee* has time to reference materials or resources to help with the decision. Once the *Head Referee* announces that their decision has been made final, the issue is over and no more appeals may be made (See rule <T1>).

- a. *Head Referees* may not review any photo or video *Match* recordings when determining a score or ruling.
- b. *Head Referees* are the only individuals permitted to explain a rule, *Disqualification*, *Violation*, warning, or other penalty to the *Teams*. *Teams* should never consult other field personnel, including *Scorekeeper Referees*, regarding a ruling clarification.

Communication and conflict resolution skills are an important life skill for *Students* to practice and learn. In VEX Robotics Competitions, we expect *Students* to practice proper conflict resolution using the proper chain of command. *Violations* of this rule may be considered a *Violation* of <G1> and/or the Code of Conduct.

Some events may choose to utilize a "question box" or other designated location for discussions with *Head Referees*. Offering a "question box" is within the discretion of the *Event Partner* and/or *Head Referee*, and may act as an alternate option for asking *Drive Team Members* to remain in the *Alliance Station* (although all other aspects of this rule apply).

However, by using this alternate location, *Drive Team Members* acknowledge that they are forfeiting the opportunity to use any contextual information involving the specific state of the field at the end of the *Match*. For example, it is impossible to appeal whether a game element was *Scored* or not if the field has already been reset. If this information is pertinent to the appeal, *Drive Team Members* should still remain in the *Alliance Station*, and relocate to the "question box" once the *Head Referee* has been made aware of the concern and/or any relevant context.

<T4> The Event Partner has ultimate authority regarding all non-gameplay decisions during an event. The Game Manual is intended to provide a set of rules for successfully playing VRC Over Under; it is not intended to be an exhaustive compilation of guidelines for running a VEX Robotics Competition event. Rules such as, but not limited to, the following examples are at the discretion of the *Event Partner* and should be treated with the same respect as the Game Manual.

- Venue access
- Pit spaces
- Health and safety
- *Team* registration and/or competition eligibility
- *Team* conduct away from competition fields

This rule exists alongside <G1>, <S1>, and <G3>. Even though there isn't a rule that says "don't steal from the concession stand," it would still be within an *Event Partner's* authority to remove a thief from the competition.

<T5> A Team's Robot and/or Drive Team Member should attend every Match. A *Robot* or a *Student* member of the *Team* must report to the field for the *Team's* assigned *Match*, even if the *Robot* is not functional. If no *Student Drive Team Members* report to the field, the *Team* will be considered a "no-show" and receive zero (0) WP's, AWP's, AP's, and SP's.

<T6> Robots at the field must be ready to play. If a *Team* brings their *Robot* to the field, it must be prepared to play (i.e., batteries charged, sized within the starting size constraint, displaying only the correct *Alliance*-color license plates, etc.).

- a. *Teams* who use VEX pneumatics must have their systems charged before they place the *Robot* on the field.
- b. *Robots* must be placed on the field promptly. Repeated failure to do so could result in a violation of <G1>. The exact definition of the term "promptly" is at the discretion of the *Head Referee* and *Event Partner*, who will consider event schedule, previous warnings or delays, etc.
- c. If a *Robot* is delaying the scheduled start of a *Match*, it may be removed from the field at the discretion of the *Head Referee* and *Event Partner*. A *Drive Team Member* may remain at the field so that the *Team* does not get assessed a "no-show" (per <T5>).

<T7> Match replays are allowed, but rare. *Match* replays (i.e., playing a *Match* over again from its start) must be agreed upon by both the *Event Partner* and *Head Referee*, and will only be issued in the most extreme circumstances. Some example situations that may warrant a *Match* replay are as follows:

- a. *Match Affecting "field fault" issues.*
 - i. Game Elements not starting in the correct positions.
 - ii. Tape lines lifting.
 - iii. Field Elements detaching or moving beyond normal tolerances (not as a result of *Robot* interactions).
 - iv. The *Autonomous Period* or *Driver Controlled Period* ending early.
 - v. Field control disconnecting or disabling *Robots*. Note, this is sometimes confused with a *Robot* whose motors have overheated, or bent pins on a controller's competition port causing intermittent drop-outs. In general, any true field fault will impact both *Alliances* simultaneously, not one *Robot* at a time.
- b. *Match Affecting game rule issues.*
 - i. *Head Referee* disables a *Robot* for a misinterpretation of a rule *Violation*.
 - ii. *Head Referee* starts the *Driver Controlled Period* of the *Match* without determining the outcome of the *Autonomous Period* winner.
 - iii. The field is reset before a score is determined.

Note: Beginning with the 2024 VEX World Championship, the V5 white screen error is no longer a permitted cause for a replay. [More information about this error can be found here.](#)

<T8> Disqualifications. When a *Team* receives a *Disqualification* in a *Qualification Match*, they receive a score of zero (0) for the *Match*, as well as zero (0) *Win Points*, *Autonomous Win Points*, *Autonomous Points*, and *Strength of Schedule Points*.

- a. If the *Team* receiving the *Disqualification* is on the winning *Alliance*, then *Teams* on the opposing *Alliance* who are not also *Disqualified* will receive the win for the *Match* and two (2) WP.
 - i. The *Team's* non-*Disqualified Alliance Partner* is unaffected, i.e. they will receive the win for the *Match* and two (2) WP.
- b. If the *Match* was a tie, then each *Team* on the opposing *Alliance* (the *Alliance* that did not receive the *Disqualification*) will receive the win for the *Match* and two (2) WP. If both *Alliances* have a *Team* receiving a *Disqualification*, then all non-*Disqualified Teams* will receive a tie for the *Match* and one (1) WP.
- c. *Autonomous Win Points* are not given to *Teams* that receive a *Disqualification*, and are not automatically awarded to the opposing *Alliance*.

When a *Team* is *Disqualified* in an *Elimination Match*, the entire *Alliance* is *Disqualified*; they receive a loss for the *Match*, and the opposing *Alliance* is awarded the win. If both *Alliances* receive a *Disqualification* in an *Elimination Match*, both *Alliances* receive a loss and will play another *Match* to determine a winner.

Note: If a Team is Disqualified in a Robot Skills Match, a score of zero (0) will be recorded for that Match.

<T9> Each Elimination Alliance gets one Time Out. Each Elimination *Alliance* gets one *Time Out*. Each *Alliance* may request one (1) *Time Out* during the *Elimination Bracket*. The *Time Out* will be served at the time of the *Alliance's* next upcoming *Match*. *Alliances* must request their *Time Out* between *Elimination Matches*, as permitted by the *Head Referee* and *Event Partner*; they may not use their *Time Out* during a *Match*, for another *Alliance's Match*, or after they have been eliminated.

<T10> Be prepared for minor field variance. Field Element tolerances and *Triballs* may vary from specified locations / dimensions; *Teams* are encouraged to design their *Robots* accordingly. Please make sure to check Appendix A for more specific nominal dimensions and tolerances.

- a. Field Element tolerances may vary from nominal by up to ± 1.0 "
- b. The opening of the *Goal* between the PVC pipe and the foam field tiles has a dimensional tolerance of $+0.25$ " / -0.00 ".
- c. *Triball* weights may vary from nominal by up to ± 20 grams.
- d. *Triball* placement at the beginning of *Matches* may vary from nominal by up to ± 1 " (25.4mm).
- e. The rotation of *Triballs* is not specified.
- f. The only placement requirement for the *Triballs* that begin in each *Match Load Zone* are that they are contacting the *Match Load Zone* (i.e., the gray foam tile). See <SG1>.

<T11> Fields may be repaired at the Event Partner's discretion. All competition fields at an event must be set up in accordance with the specifications in Appendix A and/or other applicable Appendices. Minor aesthetic customizations or repairs are permitted, provided that they do not impact gameplay (see <T4>).

Examples of permissible modifications include, but are not limited to:

- Applying threadlocker to Field Element mounting hardware
- Using tape, zip ties, or string to repair a damaged Net
- Using non-VEX white electrical tape to add required lines to the field
- Using standard 1/2" Schedule 40 PVC pipe to replace a damaged section of the *Goal*

Examples of prohibited modifications include, but are not limited to:

- Unofficial field perimeter walls, additional structural elements inside of the field perimeter, or unofficial/replica Field Elements
- Additional VEX structural parts attached to a Field Element
- An unofficial replacement net
- Replacing the opaque field walls on the VEX Portable Competition Field Perimeter with transparent panels

- Using PVC pipe of a different size or thickness to replace a damaged section of the *Goal*

Any specific repairs and/or modifications which pertain to the current season's game will be documented in this rule and Appendix A, as needed.

<T12> The red Alliance places last. The red *Alliance* has the right to place its *Robots* on the field last in both *Qualification Matches* and *Elimination Matches*. Once a *Team* has placed its *Robot* on the field, its position cannot be readjusted prior to the *Match*. If a *Team* chooses to reposition their *Robot* after it has already been placed, the opposing *Alliance* will also be given the opportunity to reposition their *Robots* promptly.

<T13> Qualification Matches follow the Match schedule. A *Qualification Match Schedule* will be available on the day of competition. The *Match Schedule* will indicate *Alliance* partners, *Match* pairings, and *Alliance* colors for each *Match*. For tournaments with multiple fields, the schedule will indicate which field each *Match* will take place on. The *Match Schedule* is subject to change at the *Event Partner's* discretion. Any multi-division event must be approved by the REC Foundation EEM/RSM prior to the event, and divisions must be assigned in sequential order by *Team* number.

<T14> Each Team will have at least six Qualification Matches

- When in a tournament, the tournament must have a minimum of six (6) *Qualification Matches* per *Team*. The suggested amount of *Qualification Matches* per *Team* for a standard tournament is eight (8) and up to ten (10) for a championship event.
- When in a league, there must be at least three (3) league ranking sessions, with at least one (1) week between sessions. Each session must have a minimum of two (2) *Qualification Matches* per *Team*. The suggested amount of *Qualification Matches* per *Team* for a standard league ranking session is four (4). Leagues will have a championship session where elimination rounds will be played. *Event Partners* may choose to have *Qualification Matches* as part of their championship session.

<T15> Qualification Matches contribute to a Team's ranking for Alliance Selection

- When in a tournament, every *Team* will be ranked based on the same number of *Qualification Matches*.
- When in a league, every *Team* will be ranked based on the number of *Matches* played. *Teams* that participate at least 60% of the total *Matches* available will be ranked above *Teams* that participate in less than 60% of the total *Matches* available; e.g., if the league offers 3 ranking sessions with 4 *Qualification Matches* per *Team*, teams that participate in 8 or more *Matches* will be ranked higher than *Teams* who participate in 7 or fewer *Matches*. Being a no-show to a *Match* that a *Team* is scheduled in still constitutes participation for these calculations.
- In some cases, a *Team* will be asked to play an additional *Qualification Match*. The extra *Match* will be identified on the *Match Schedule* with an asterisk; WP's, AP's, and SP's for that *Qualification*

Match will not impact a *Team's* ranking, and will not affect participation percentage for leagues.

- i. *Teams* are reminded that <G1> is always in effect and *Teams* are expected to behave as if the additional *Qualification Match* counted.
- ii. In Leagues, *Teams* may have a different number of *Qualification Matches*. Rankings are determined by the *Win Percentage*, which is the number of wins divided by the number of *Qualification Matches* that *Teams* has played.

<T16> Qualification Match tiebreakers. *Team* rankings are determined throughout *Qualification Matches* as follows:

- a. Average *Win Points* (WP / Number of *Matches* played)
- b. Average *Autonomous Points* (AP / Number of *Matches* played)
- c. Average *Strength of Schedule Points* (SP / Number of *Matches* played)
- d. Highest *Match* score
- e. Second highest *Match* score
- f. Random electronic draw

<T17> Send a Student representative to Alliance Selection. Each *Team* must send one (1) *Student* representative to the playing field (or other designated area) to participate in *Alliance Selection*. If the *Team* Representative fails to report in for *Alliance Selection*, their *Team* will be ineligible for participation in the *Alliance Selection* process.

<T18> Each Team may only be invited once to join one Alliance. If a *Team* representative declines an *Alliance Captain's* invitation during *Alliance Selection*, that *Team* is no longer eligible to be selected by another *Alliance Captain*. However, they are still eligible to play *Elimination Matches* as an *Alliance Captain*.

For example:

- *Alliance Captain 1* invites *Team ABC* to join their *Alliance*.
- *Team ABC* declines the invitation.
- No other *Alliance Captains* may invite *Team ABC* to join their *Alliance*.
- However, *Team ABC* may still form their own *Alliance*, if *Team ABC* ranked high enough after *Qualification Matches* to become an *Alliance Captain*.

<T19> Elimination Matches follow the Elimination Bracket. A sixteen (16) *Alliance* bracket plays as shown in Figure 38:

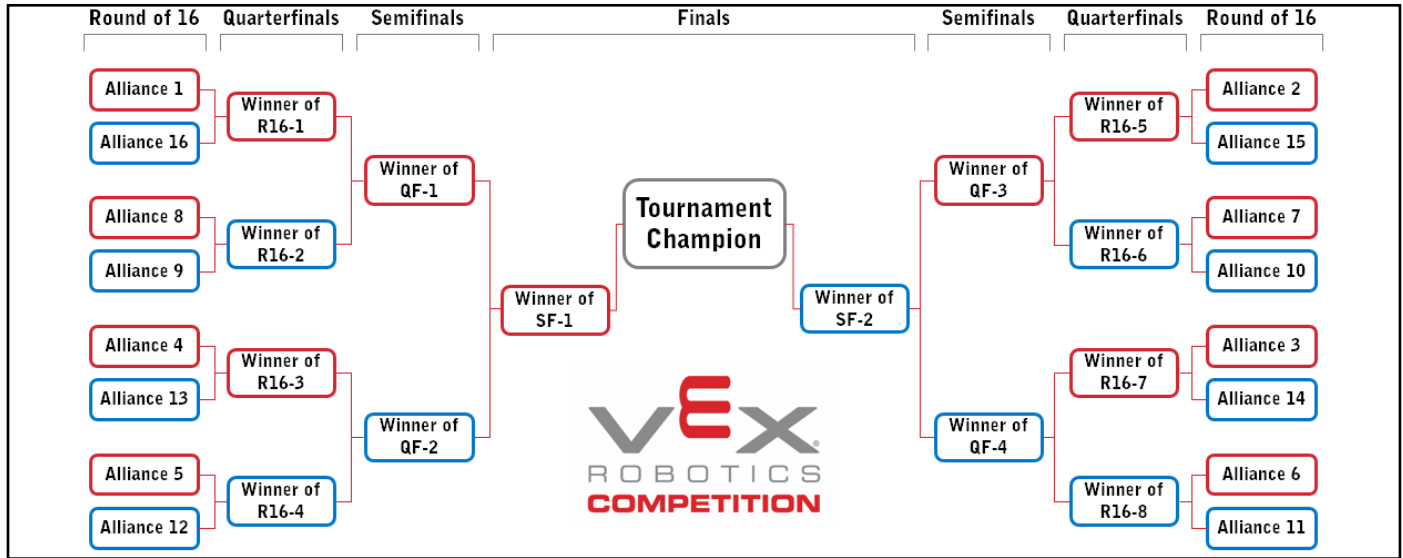

Figure 38: A 16-Alliance bracket

If an event is run with fewer than sixteen (16) *Alliances*, then they will use the bracket shown above, with *Byes* awarded when there is no applicable *Alliance*. For example, in a tournament with twelve (12) *Alliances*, *Alliances* 1, 2, 3, & 4 would automatically advance to the Quarterfinals.

Thus, an eight (8) *Alliance* bracket would run as shown in Figure 39:

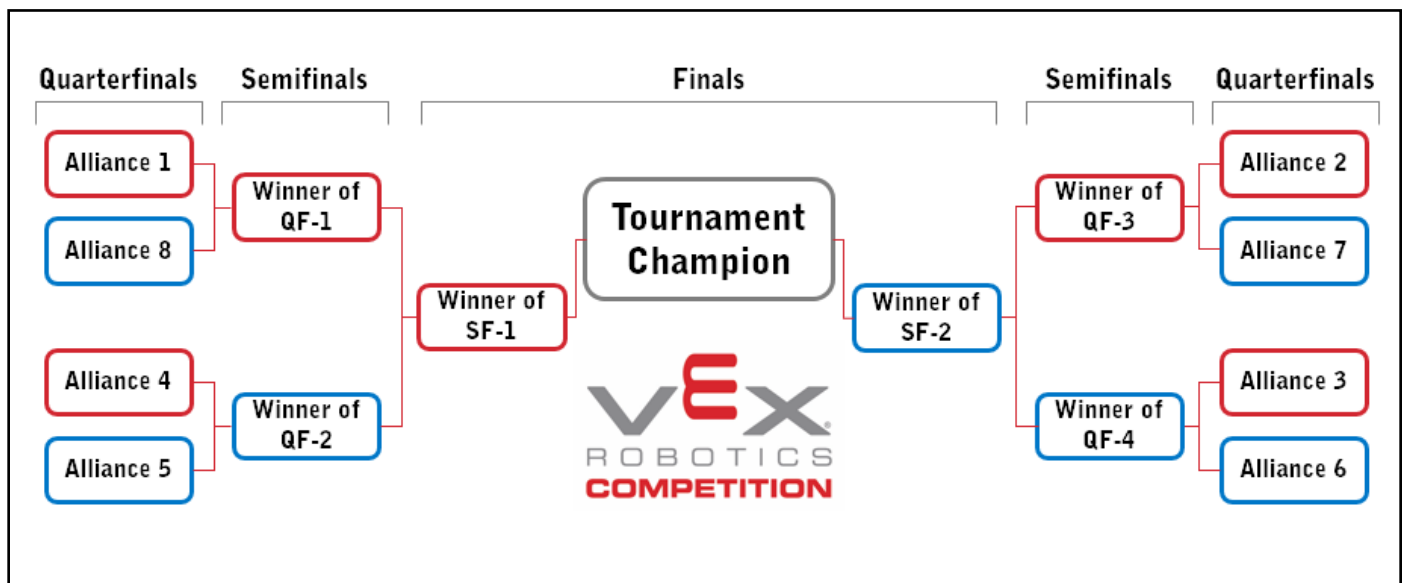

Figure 39: An 8-Alliance bracket

<T20> **Elimination Matches are a blend of "Best of 1" and "Best of 3."** "Best of 1" means that the winning *Alliance* in each *Match* advances to the next round of the *Elimination Bracket*. "Best of 3" means that the first *Alliance* to reach two wins will advance.

See the Flowchart in Figure 40 for more information.

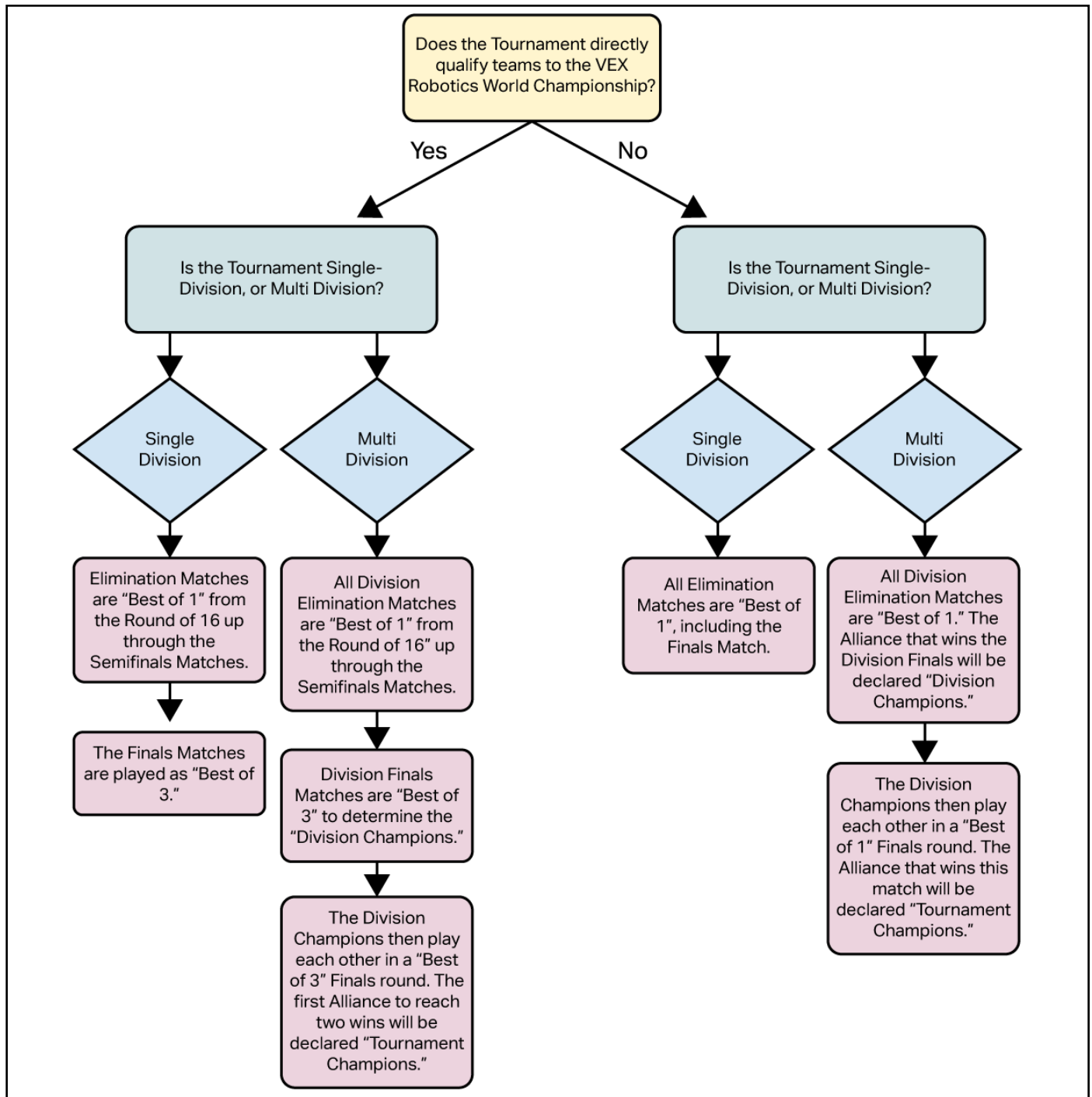

Figure 40: The process for determining how Elimination Matches should be played.

<T21> Small tournaments may have fewer Alliances. The number of *Alliances* for a given event is determined as follows:

# of Teams	# of Elimination Alliances
32+	16
24-31	12
16-23	8
<16	# of <i>Teams</i> divided by 2, less any remainder

<T22> Fields at an event must be consistent with each other. There are many types of permissible aesthetic and/or logistical modifications that may be made to competition fields at the *Event Partner's* discretion. If an event has multiple Head-to-Head competition fields, they must all incorporate the same permissible/applicable modifications. For example, if one field is elevated, then all Head-to-Head competition fields must be elevated to the same height.

Examples of these modifications may include, but are not limited to:

- Elevating the playing field off of the floor (common heights are 12" to 24" [30.5cm to 61cm])
- Field control systems (see <T23>)
- Field display monitors
- Field perimeter decorations (e.g., LED lights, sponsor decals on polycarbonate panels)
- Field perimeter type (see <T24>)
- Utilizing the VEX GPS Field Code Strips

Note: If an event has dedicated fields for Skills Challenge Matches, there is no requirement for them to have the same consistent modifications as the Head-to-Head fields. See <RSC6> for more details.

<T23> There are three types of field control that may be used:

1. A VEXnet Field Controller controlled by Tournament Manager, which connects to a Controller's competition port via ethernet cable.
2. A V5 Event Brain controlled by Tournament Manager, which connects to a Controller via Smart Cable.
3. A VEXnet Competition Switch, which connects to a Controller's competition port via Cat-5 cable, may only be used in *Practice Matches* or *Robot Skills Matches*, and only under extreme circumstances.

If an event has multiple fields, then all fields of the same game type must use the same control system, in accordance with <T23> and <RSC6>. For example, it would be permissible for Head-to-Head competition fields to use V5 Event Brains, and for Skills Challenge fields to use VEXnet Field Controllers. However, it would not be permissible for one Head-to-Head field to use a V5 Event Brain while another Head-to-Head field uses a VEXnet Field Controller.

Note: Official Qualifying Events may only use the official, unmodified version of Tournament Manager for field control, along with approved hardware and networking solutions found in the REC Library.

Note 2: Add-ons that abide by the [TM Public API guidelines](#) are permitted. Once add-ons are enabled, the software is no longer supported by the REC Foundation, VEX Robotics, or DWAB Technologies; any necessary troubleshooting will be done at the user's own risk.

<T24>There are two types of Field Perimeter that may be used:

1. VEX Metal Competition Field Perimeter (SKU 278-1501)
2. VEX Portable Competition Field Perimeter (SKU 276-8242)

See Appendix A for more details.

If an event has multiple fields, then all fields of the same game type must use the same Field Perimeter type, in accordance with <T22> and <RSC6>. For example, it would be permissible for Head-to-Head competition fields to use metal Field Perimeters, and for Skills Challenge fields to use Portable Field Perimeters. However, it would not be permissible for one Head-to-Head field to use a metal Field Perimeter, while other Head-to-Head fields use Portable Field Perimeters.

Note: See <RSC6> for more details specific to Skills Challenge fields.

Section 5

VEX Worlds 2024 Update

Competition Fields

- All head-to-head and Robot Skills Challenge fields will be set up using the Portable Competition Field Perimeter.
- All head-to-head and Robot Skills Challenge fields will utilize the VRC Smart Field Control System. More information can be found [here](#).
- All head-to-head fields will be elevated to a height of 24".
- All elements that are normally attached to metal plates below the field tiles will be bolted to the field risers for all head-to-head competition fields.

Robots & Inspection

- The full Robot Inspection Checklist can be found [here](#).
- V5 Robot Brains and Controllers must be running VEXos firmware 1.1.3 or higher.
- *Team* numbers must be set on V5 Robot Brains.
- Robot Skills Challenge fields will require the use of Bluetooth mode. More information can be found [here](#).
- *Robot* starting sizes will be checked using the official VEX Robotics On-Field Robot Expansion Sizing Tool (276-5942).

Robot Skills Challenge

- In *Robot Skills Matches*, *Teams* will get a verbal warning for the first <SG6> *Violation* in each *Match*. Any additional <SG6> *Violations* during a *Robot Skills Match* will result in a score of 0 for that *Match*.

Tournament Structure (Divisions)

The 2024 VEX Robotics World Championship will consist of the following divisions:

- VRC High School: 10 divisions
- VRC Middle School: 6 divisions
- VRC JROTC: 2 divisions
- VEX U: 2 divisions

To determine Division Champions, each division will play as a separate standalone tournament.

- Each division will have 16 Elimination *Alliances* (or 16 Elimination *Teams*, in VEX U divisions).
- *Elimination Matches* are “Best of 1” from Round-of-16 up through the Semi-Finals *Matches*.
- The Division Finals *Matches* are played as a “Best of 3”, and an *Alliance* needs two wins to receive the title of Division Champion.

To seed the Overall Finals bracket, Divisions will be ranked/seeded based on the following criteria:

1. Average points accumulated by all *Teams* in a Division during their *Qualification Matches*.
2. Average points accumulated by the winning *Alliance* (or VEX U *Team*) in *Qualification Matches*.
3. Total *Autonomous Win Points* by all *Teams* in a Division during their *Qualification Matches*.

This ranking will be updated throughout the *Qualification Matches* and displayed within divisions for *Teams* to reference.

Tournament Structure (Overall Finals / "VEX Dome")

- To determine the World Champions, the Division Champions within each grade level will play each other in a standard *Elimination Bracket* (shown below for reference), seeded as explained above. For grade levels with only two divisions (JROTC and VEX U), the Overall Finals will be a standard set "Best of 3" *Matches*.
- During the Overall Finals tournament, no *Time Outs* will be permitted. Any *Alliances* playing in back-to-back *Matches* (e.g., during the Best-of-3 Finals) will have a minimum of 5 minutes from the time their *Match* score is shown until the next *Match* is scheduled to begin.
- Most *Minor Violations* given during *Division Matches* will persist into the Overall Finals, just as they would persist between *Qualification Matches* and *Elimination Matches* in a standard tournament.

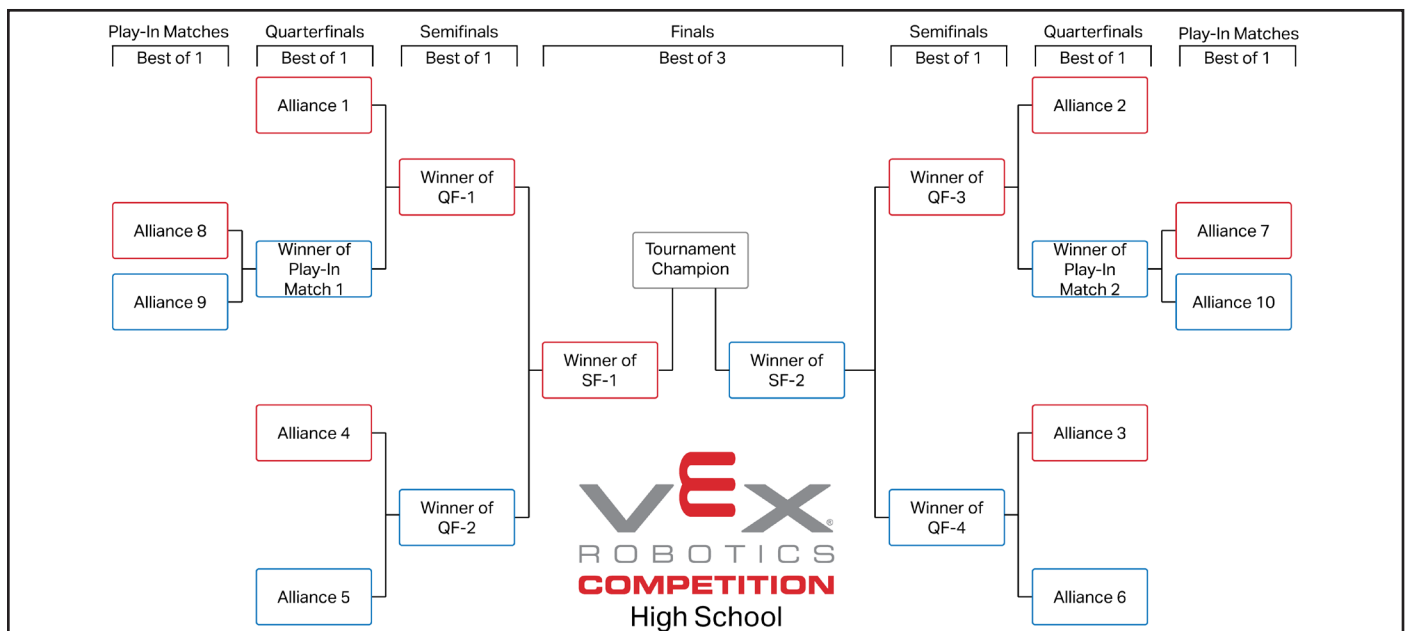
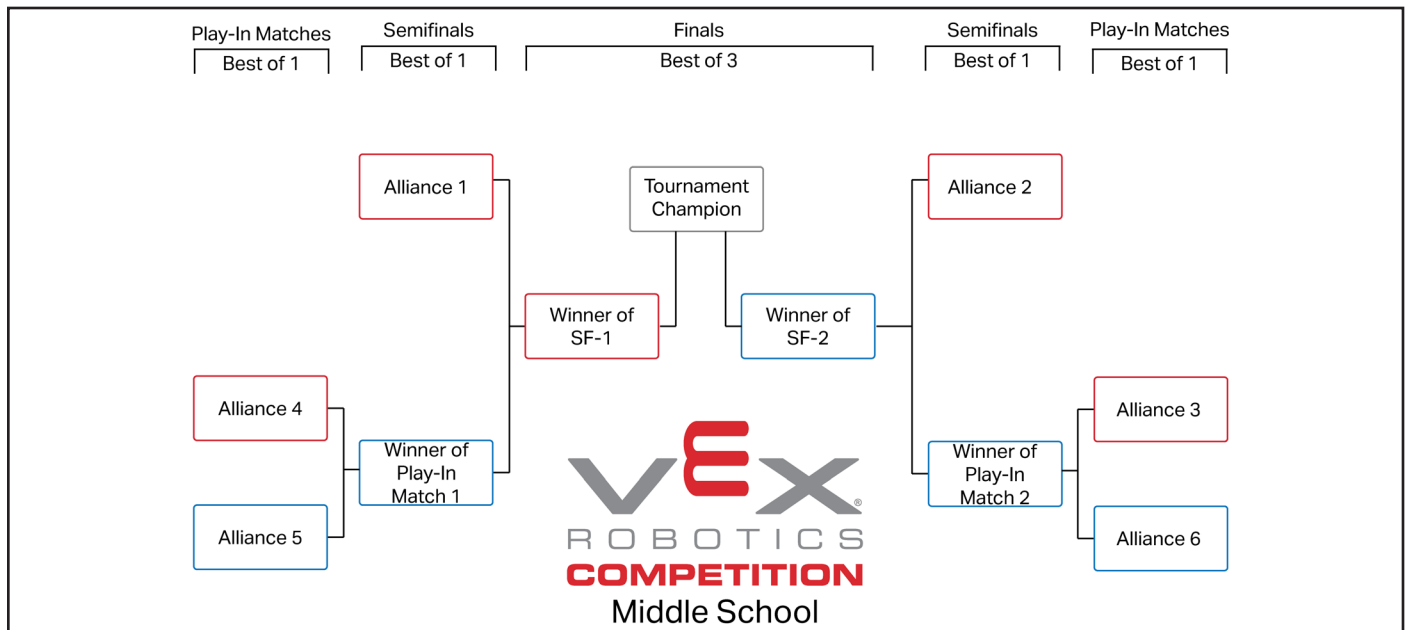

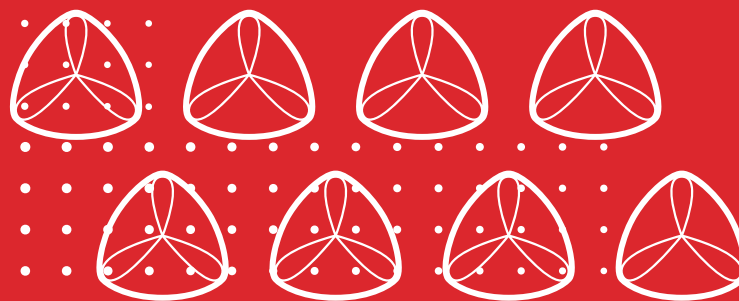

2023 - 2024

Appendix A - Field Overview and Specifications

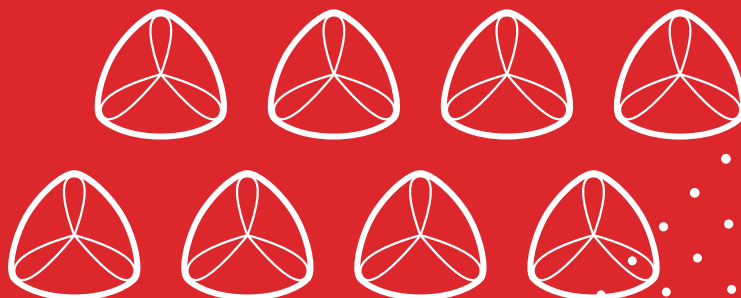

Appendix A - Field Overview

Game Field Introduction

This document will provide Bill of Materials (BOM) information and detailed specifications for the Official Competition Field.

Teams who do not need an “official” field should refer to the separate low-cost field guide for cost reduction options. *Teams* assembling the full field should refer to the separate VEX Robotics Competition Over Under Field Build Instructions.

Please note: this field can utilize both the [VEX Portable Competition Field Perimeter \(276-8242\)](#) and the VEX Competition Field Perimeter (278-1501) developed by VEX Robotics. Instructions and specifications for these field perimeters are available in separate documents and are important for the field assembly.

This document is divided up into three sections:

1. Field Overview
2. Field BOM
3. Field Specifications

There is also an accompanying STEP file which can be imported into most 3D modeling programs (e.g., Inventor, Sketchup, Solidworks, etc.). This 3D model shows the “official” setup of a VEX Robotics Competition - Over Under competition field, as well as detailed models of individual Field Elements.

For additional game-play detail, please refer to the VEX Robotics Competition Over Under Game Manual.

Field Overview

The game VEX Robotics Competition Over Under is played on a 12ft x 12ft foam mat, surrounded by a perimeter, and divided in half by a barrier spanning the length of the field.

The VRC Over Under field consists of sixty (60) Triballs. Each Alliance has one (1) Goal, two (2) Match Load Zones and one (1) set of Alliance Elevation Bars. Each half of the field includes an Offensive Zone, which is partially defined by the Barrier and Goals. A Goal is located alongside the wall closest to each Alliance Station.

For more details and specific gameplay rules, please refer to the VEX Robotics Competition Over Under Game Manual.

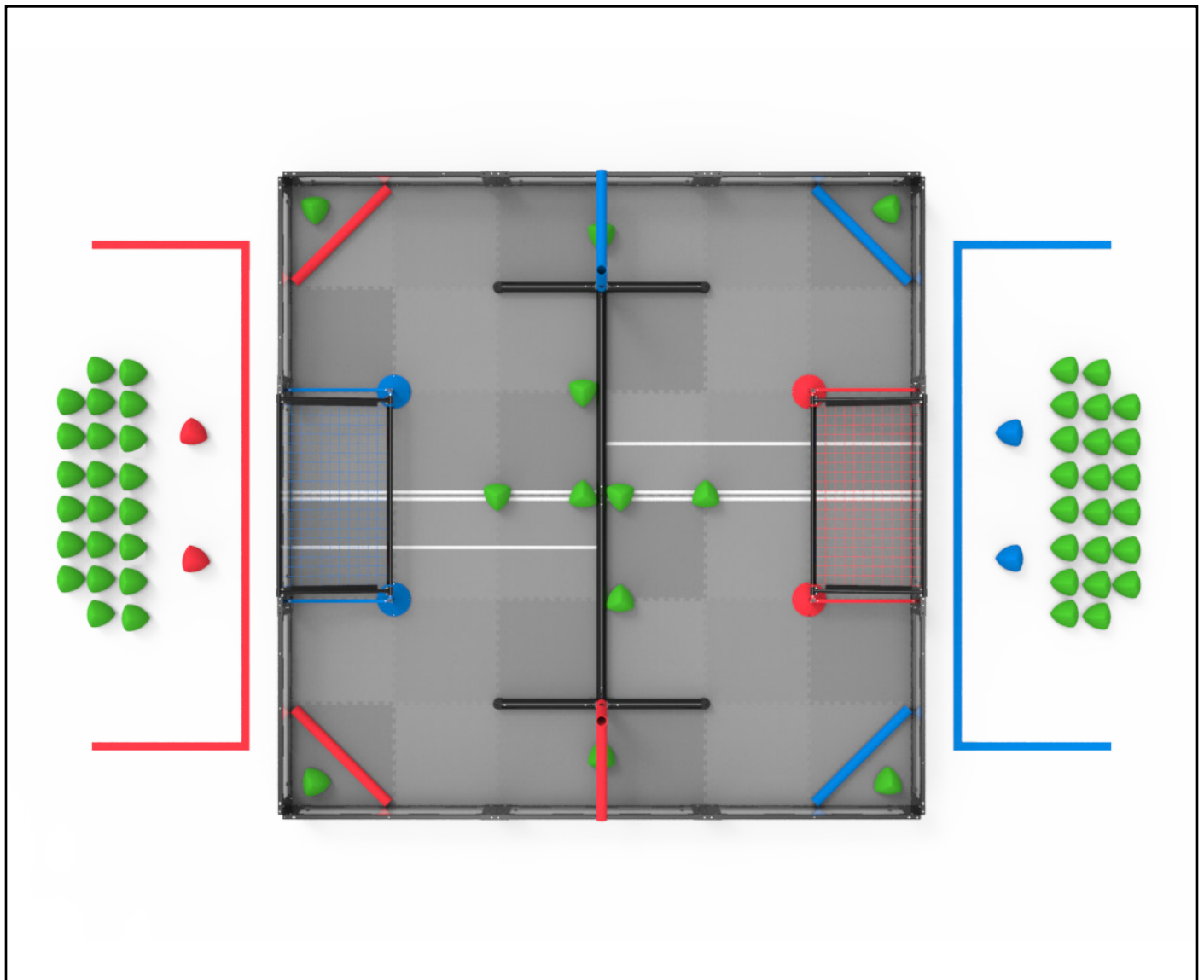

Game Objects & Field Bill of Materials

All of these items are available for purchase from www.vexrobotics.com

Generic Field Elements - Reusable Each Year

Part Number	Description
278-1501	VRC Field Perimeter Frame & Hardware
276-8242	VRC Portable Competition Field Perimeter
276-6905	VRC Anti-Static Field Tiles (18-Pack)
275-1401	VRC VEXnet Field Controller

Official VEX Robotics Competition Over Under Specific Elements

Part Number	Description	Quantity per Full Field
276-8354	VRC Over Under Full Field & Game Element Kit	
276-8355	VRC Over Under Game Element Kit	2
276-8356	VRC Over Under Field Element Kit 1	1
276-8357	VRC Over Under Field Element Kit 2	1
276-8905	VRC Over Under Field Element Kit 3	1

Practice Elements

Part Number	Description
276-8355	VRC Over Under Game Element Kit
276-8358	VRC Over Under Scoring Element Kit

Field Specifications Introduction

This section will outline the specifications that are most important to *Teams* designing a *Robot* to compete in the VEX Robotics Competition Over Under. Though many of the critical dimensions are included in this section, it may be necessary to consult the separate assembly guide and 3D CAD models of the field for an additional level of detail. If you can't find a dimension in the specifications, we include a full model of the field to "virtually" measure whatever dimension is necessary.

Field components may vary slightly from event to event. This is to be expected; *Teams* will need to adapt accordingly. It is good design practice to create mechanisms capable of accommodating variances in the field and game pieces.

Note: Minor field repairs are permissible, provided that the repairs do not affect gameplay. Examples of minor field repairs include (but are not limited to) threadlocker applied to Field Element mounting hardware or tape over a hole in a damaged Net. Be sure to check the Official Q&A for specific examples or to get an official clarification.

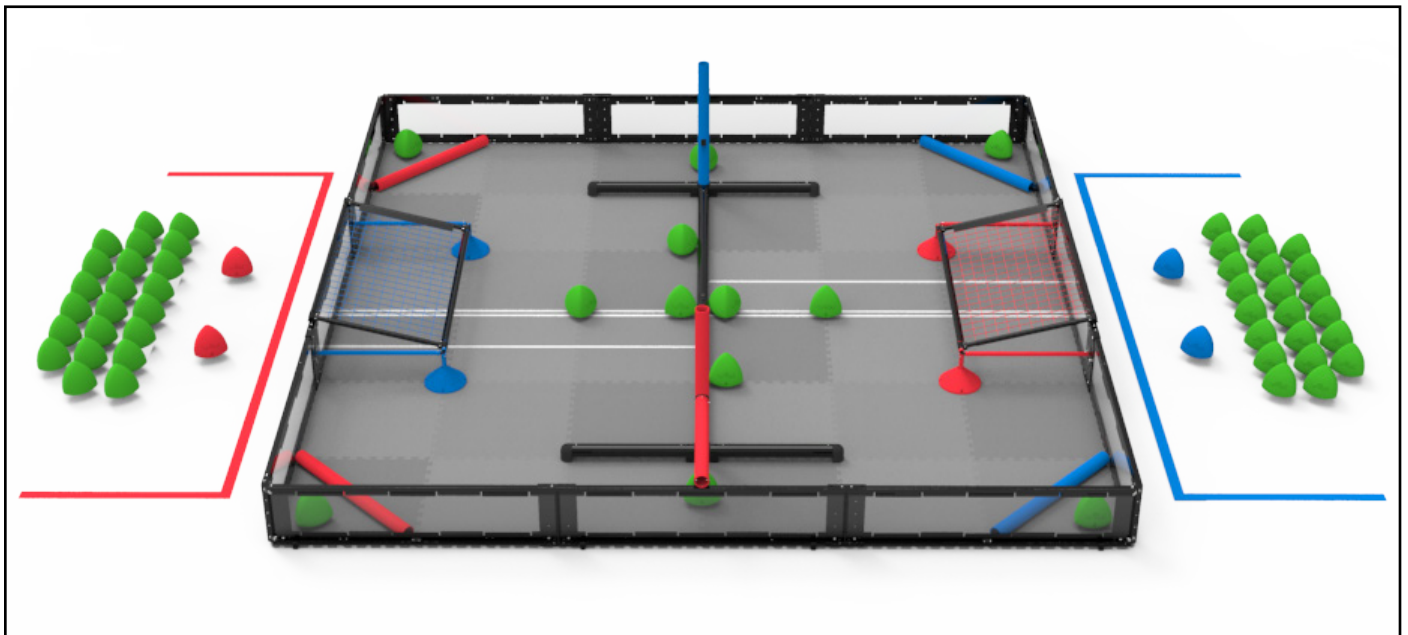

Helpful Tips to Ensure Proper Goal Performance

Making sure the *Goals* for Over Under are appropriately built, assembled, and performing properly is crucial to gameplay. Here are some tips to make sure that *Goals* are built properly and interact with *Triballs* as intended.

1. Make sure the field walls are sitting flush to the ground/field riser and the field tiles. There should be no gaps between the field walls and the floor, and/or the field tiles and the field walls. Please refer to the figures later in this appendix for the cross-section of how the field walls and field tiles are supposed to fit together.
2. Make sure that the short vertical pipes are fully inserted into the bases that assemble to the field tiles. This can be measured by making sure the length of the pipe coming out of the base matches the dimensions provided in this appendix. *Event Partners* should periodically check this joint to ensure the *Goal* is not rising up out of the base over the course of an event.
3. After assembly, manipulate a *Triball* by hand to ensure there is a slight interference between the *Goal* and the *Triball* around the entire perimeter of the *Goal*. If any *Triballs* slide in without interference anywhere along the perimeter of the *Goal*, the *Goal* is not built properly and must be reviewed and repaired.
4. Measure the pipes to ensure they are within the specified tolerance band along the entire perimeter. The measurement should be taken from the bottom of the pipe to the field tiles. Please reference the figures later in this appendix and <T10> to ensure your measurements match the acceptable tolerances for height of the *Goal*.

Accessibility Note - Marking Alliance Triballs

A 1-2" black circle may be added to the corners of *Alliance Triballs* (e.g., with permanent marker) to help competitors with red-green color blindness differentiate between *Triball* types. Please remember to contact your *Event Partner* or REC Foundation Event Engagement Manager with any accommodation requests prior to your event.



Scoring Objects are placed as follows before the start of each Match

1. (2x) Alliance colored triballs for preload. One per team.
2. (22x) Triballs outside the field for Alliance match loads.
3. (1x) Triball centered under the low elevation bar.
4. (1x) Triball touching the Barrier half way between the Autonomous Line and the Elevation Bar on the side of the Autonomous Line without a neutral zone.
5. (1x) Triball touching the Barrier and the Autonomous Line.
6. (1x) Triball between the Goal and the Barrier on the Autonomous Line.
7. (1x) Triball in each Match Load Zone.

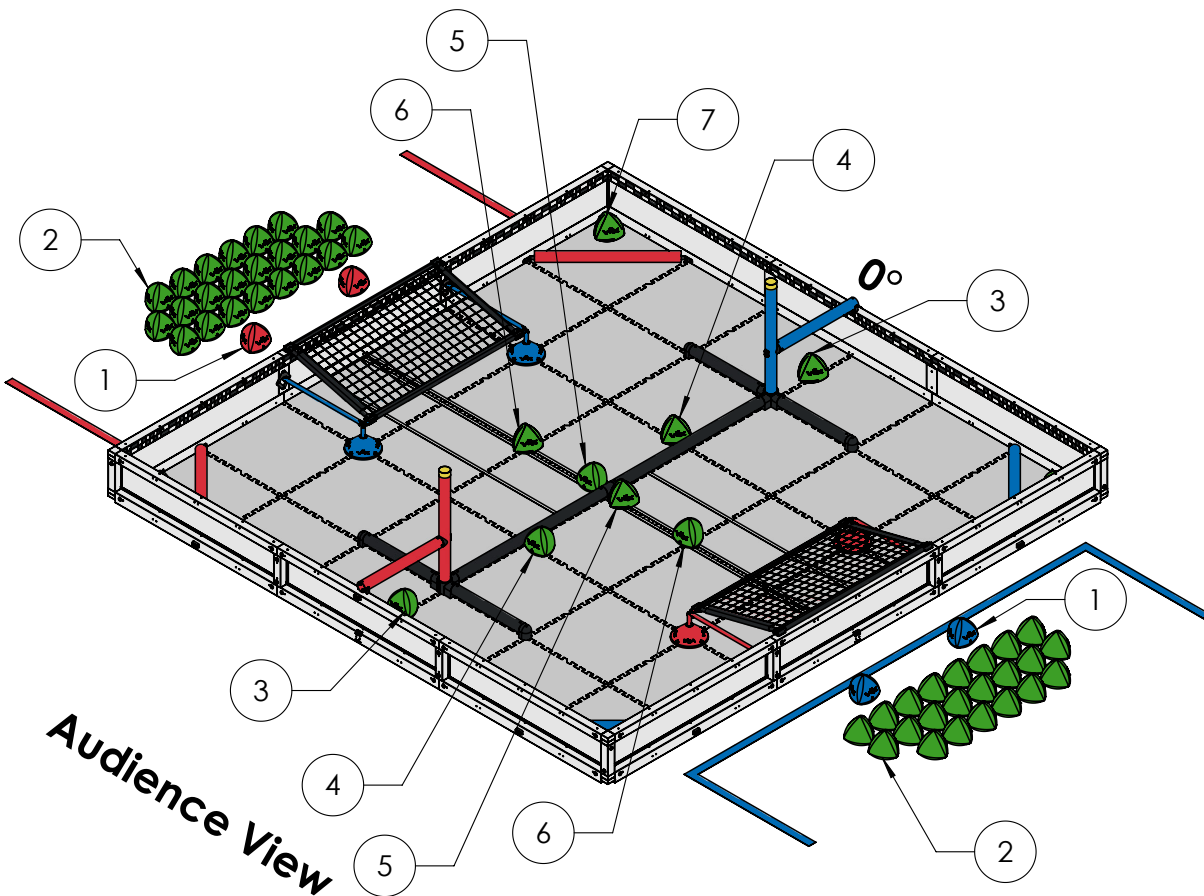

Audience View

	Description 2023-2024 Game Object Placement	
	Dwg No 276-8354-000 Field Specifications	
	Competition VRC 2023-2024	Sheet 1 of 15
	Release 6/23/2023	ALL DIMENSIONS ARE IN INCHES. www.VEXROBOTICS.COM

Note: The yellow Elevation Bar Cap was removed from VRC fields in version 3.0 of the Game Manual.

Reference Object Placement Image:

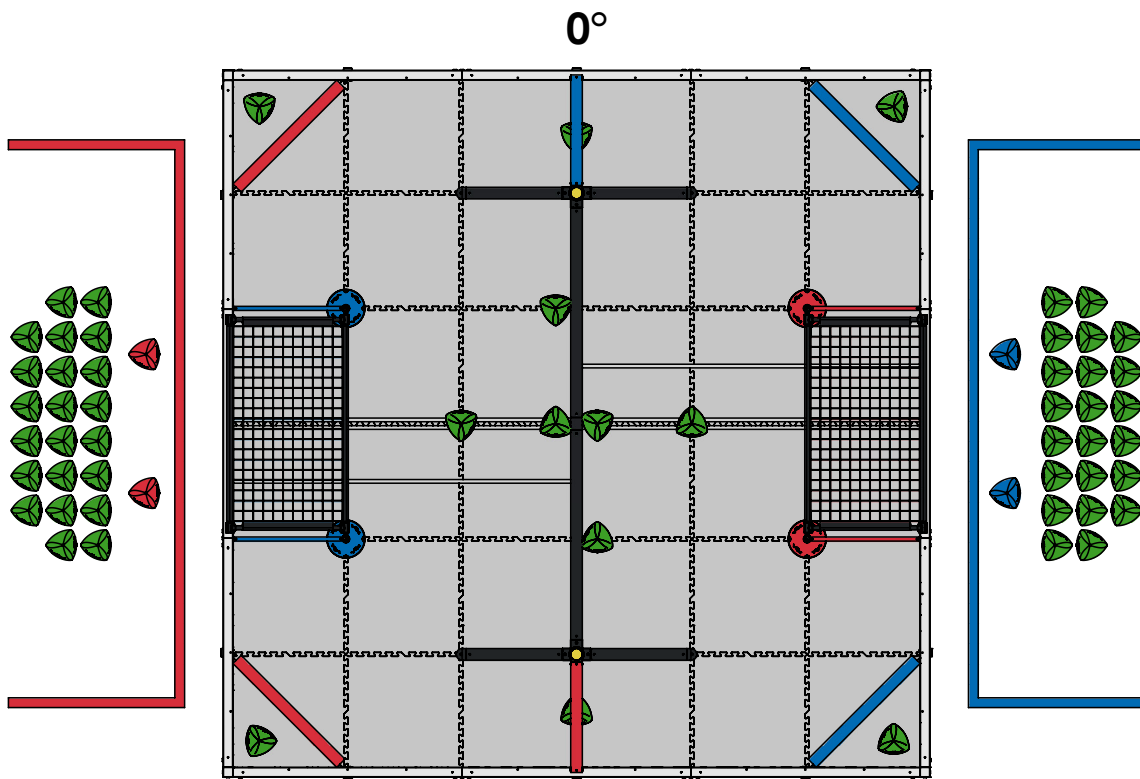

Audience View

	Description 2023-2024 Game Object Placement (2)	
	Dwg No 276-8354-000 Field Specifications	
	Competition VRC 2023-2024	Sheet 2 of 15
	Release 6/23/2023	ALL DIMENSIONS ARE IN INCHES.
		WWW.VEXROBOTICS.COM

Note: The yellow Elevation Bar Cap was removed from VRC fields in version 3.0 of the Game Manual.

Reference Object Placement Skills Layout Image:

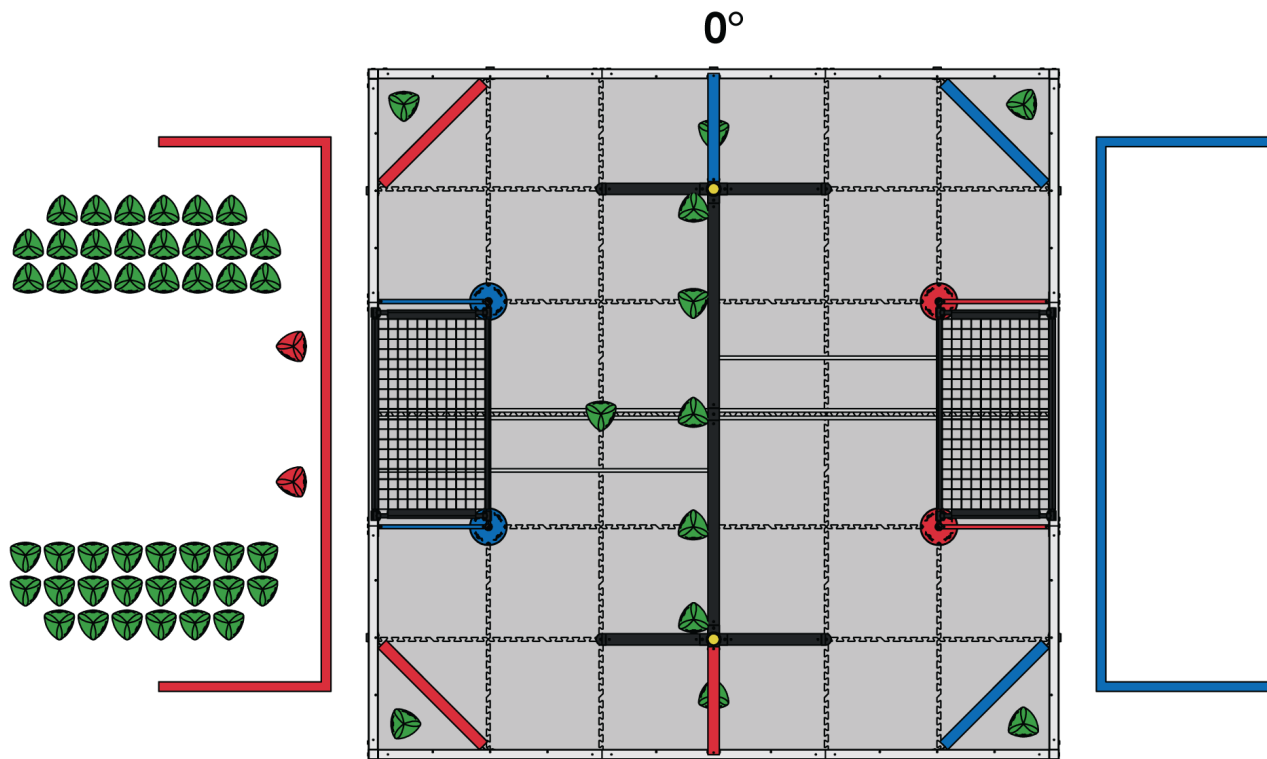

Audience View

	Description 2023-2024 Game Object Placement (3)	
	Dwg No 276-8354-000 Field Specifications	
	Competition VRC 2023-2024	Sheet 3 of 15
	Release 6/23/2023	ALL DIMENSIONS ARE IN INCHES.

www.VEXROBOTICS.com

Note: The yellow Elevation Bar Cap was removed from VRC fields in version 3.0 of the Game Manual.

Field Critical Specs (276- 8242):

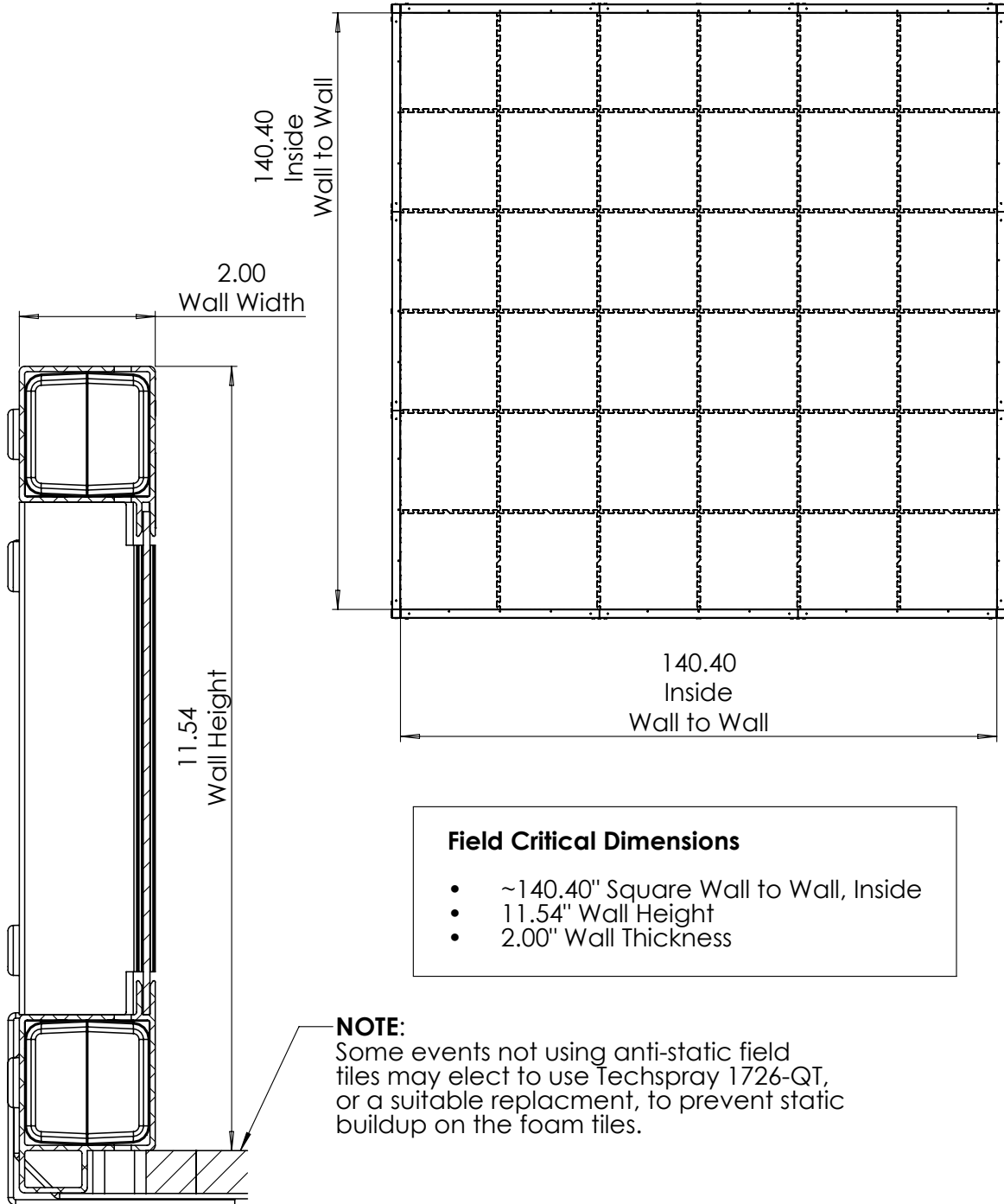

- Field Critical Dimensions**
- ~140.40" Square Wall to Wall, Inside
 - 11.54" Wall Height
 - 2.00" Wall Thickness

NOTE:
Some events not using anti-static field tiles may elect to use Techspray 1726-QT, or a suitable replacement, to prevent static buildup on the foam tiles.

	Description		Field Perimeter Specifications
	Dwg No		276-8354-000 Field Specifications
	Competition	VRC 2023-2024	Sheet 4 of 15
	Release	6/23/2023	ALL DIMENSIONS ARE IN INCHES.
			www.VEXROBOTICS.COM

Field Critical Specs (278- 1501):

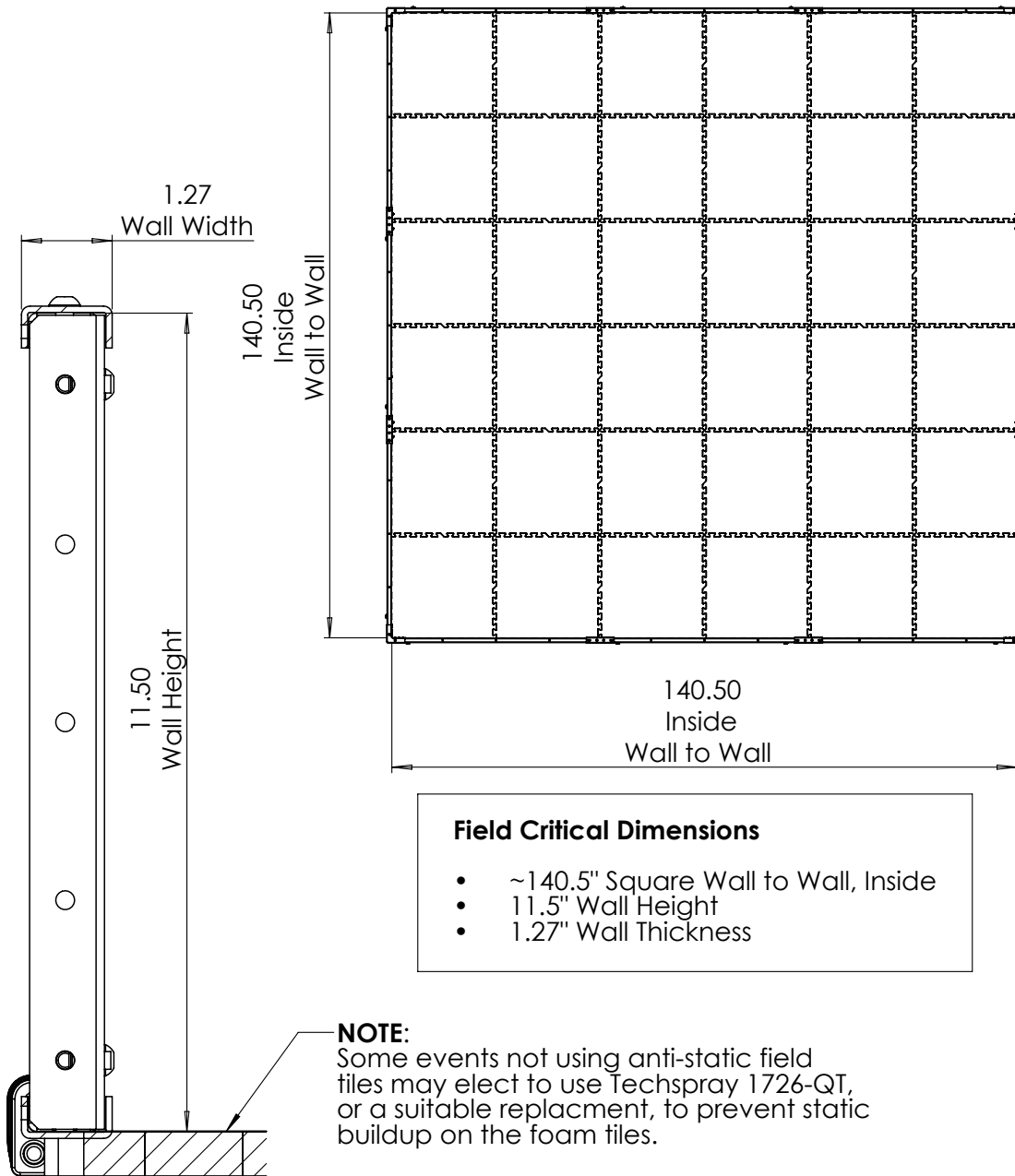

	Description		Field Perimeter Specifications (2)
	Dwg No		276-8354-000 Field Specifications
	Competition	VRC 2023-2024	Sheet 5 of 15
	Release	6/23/2023	ALL DIMENSIONS ARE IN INCHES.

www.VEXROBOTICS.COM

Triball Specs:

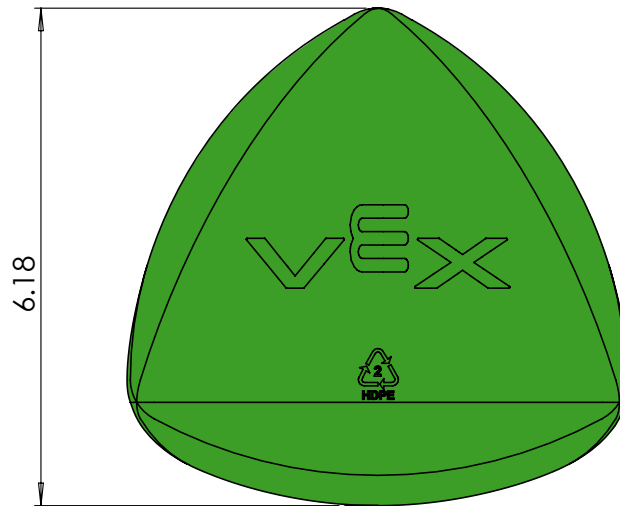
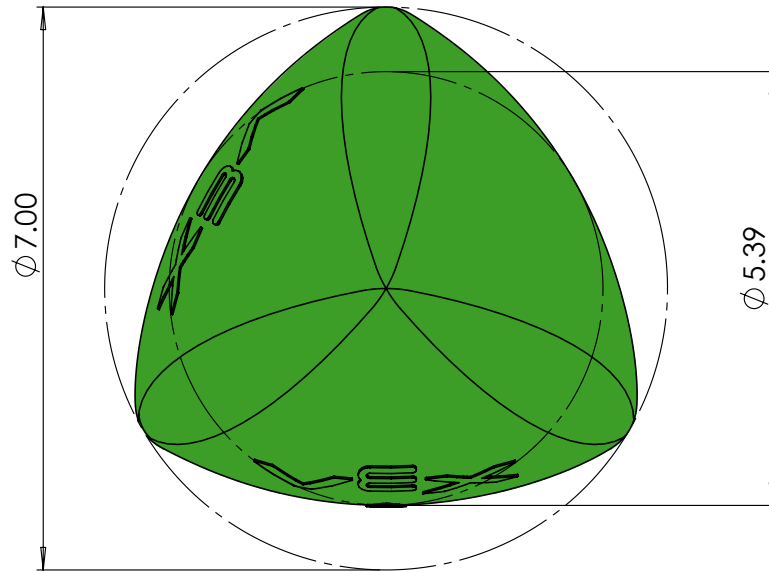

Mass: 110 ± 20 Grams

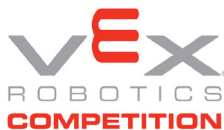

Description	2023-2024 Game Specifications	
Dwg No	276-8354-000 Field Specifications	
Competition	VRC 2023-2024	Sheet 6 of 15
Release	6/23/2023	ALL DIMENSIONS ARE IN INCHES.

[WWW.VEXROBOTICS.COM](http://www.VEXROBOTICS.COM)

Goal Specs:

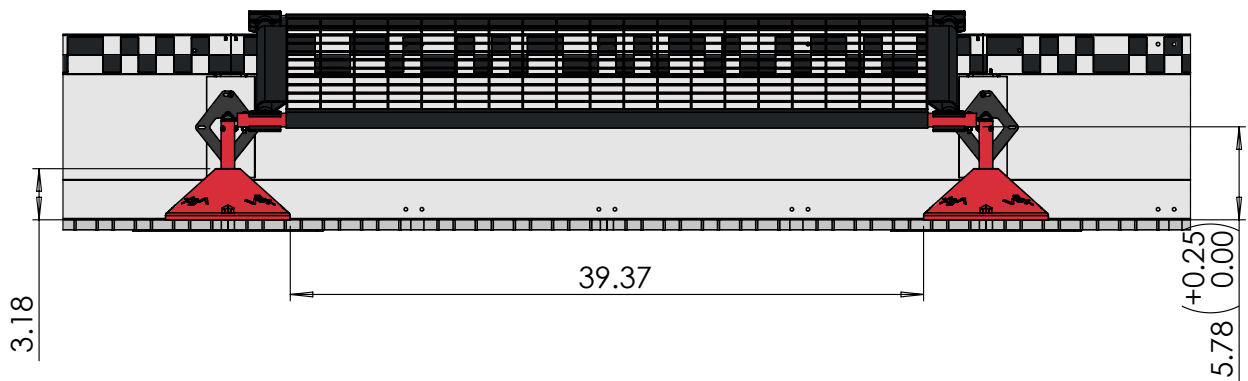
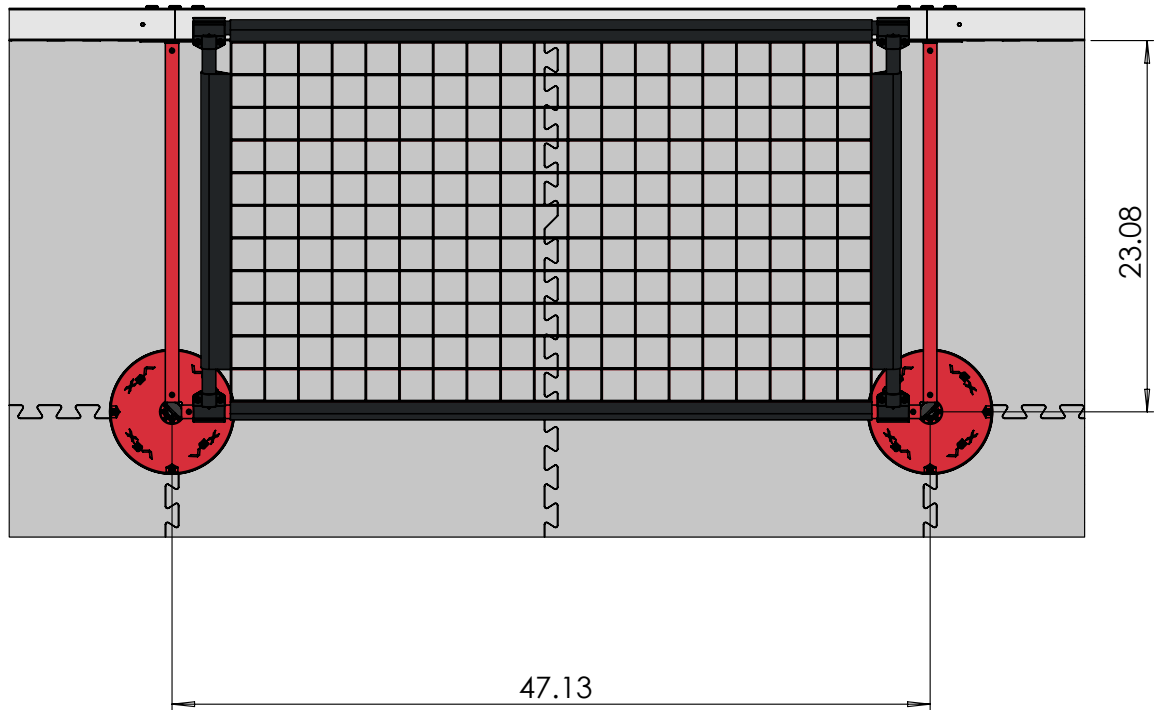

Description	2023-2024 Game Specifications (2)	
Dwg No	276-8354-000 Field Specifications	
Competition	VRC 2023-2024	Sheet 7 of 15
Release	6/23/2023	ALL DIMENSIONS ARE IN INCHES.

www.VEXROBOTICS.COM

Goal Specs:

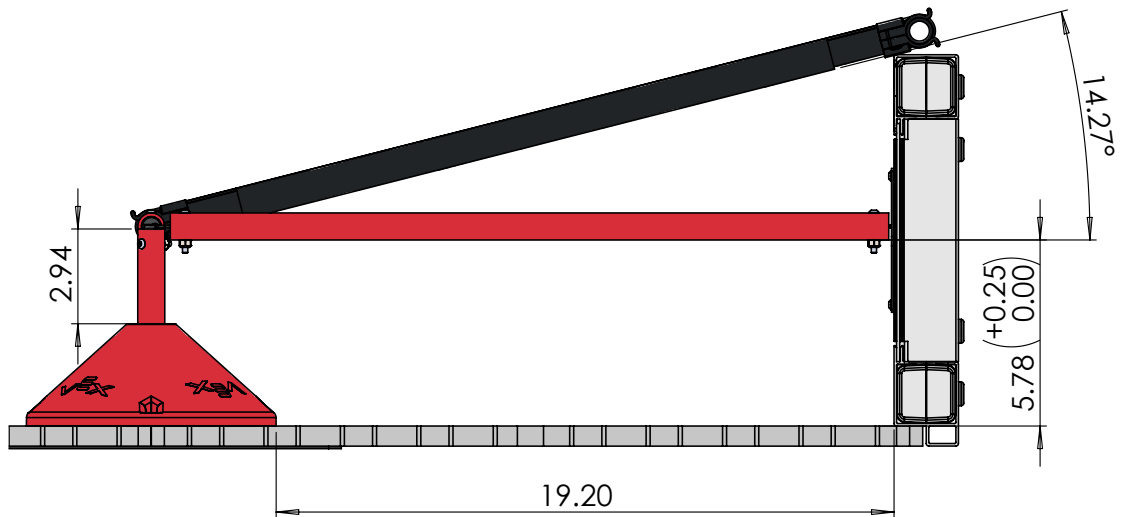

	Description 2023-2024 Game Specifications (3)	
	Dwg No 276-8354-000 Field Specifications	
	Competition VRC 2023-2024	Sheet 8 of 15
	Release 6/23/2023	ALL DIMENSIONS ARE IN INCHES.

www.VEXROBOTICS.com

Barrier Specs:

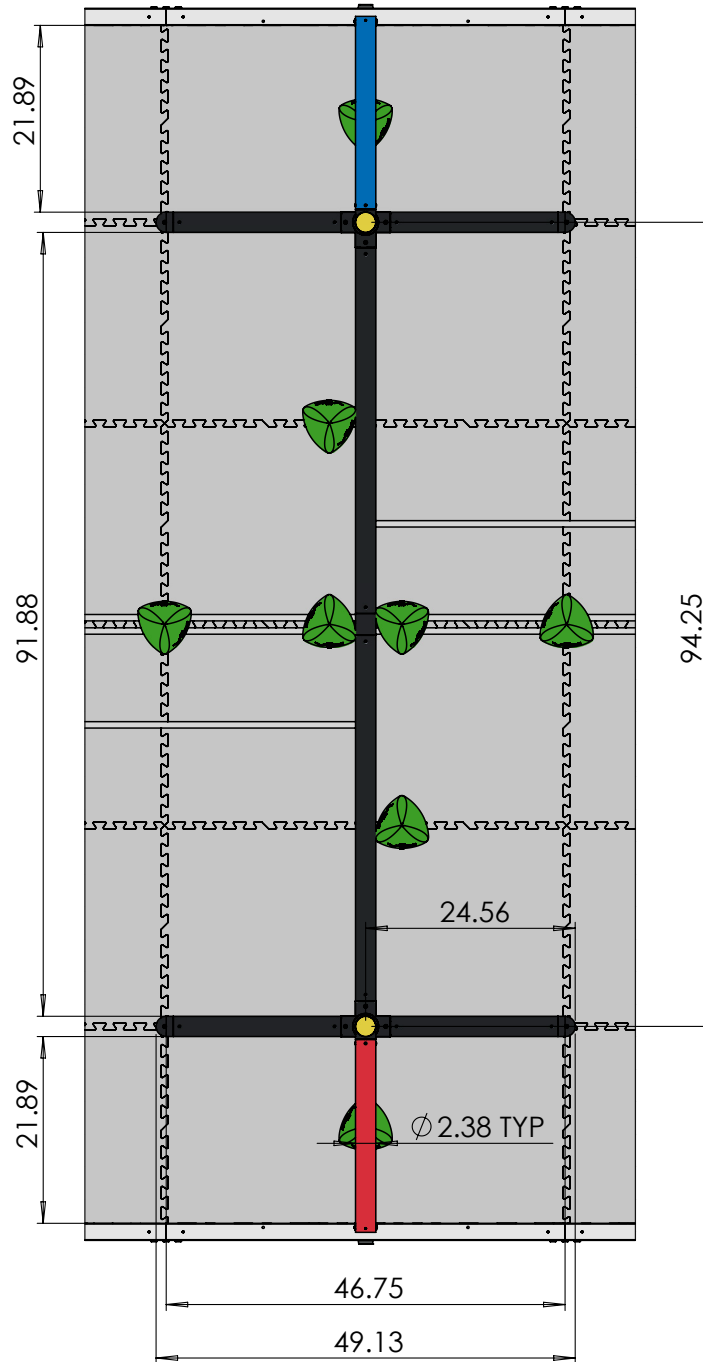

	Description 2023-2024 Game Specifications (4)	
	Dwg No 276-8354-000 Field Specifications	
	Competition VRC 2023-2024	Sheet 9 of 15
	Release 6/23/2023	ALL DIMENSIONS ARE IN INCHES.
www.VEXROBOTICS.COM		

Note: The yellow Elevation Bar Cap was removed from VRC fields in version 3.0 of the Game Manual.

Barrier Specs:

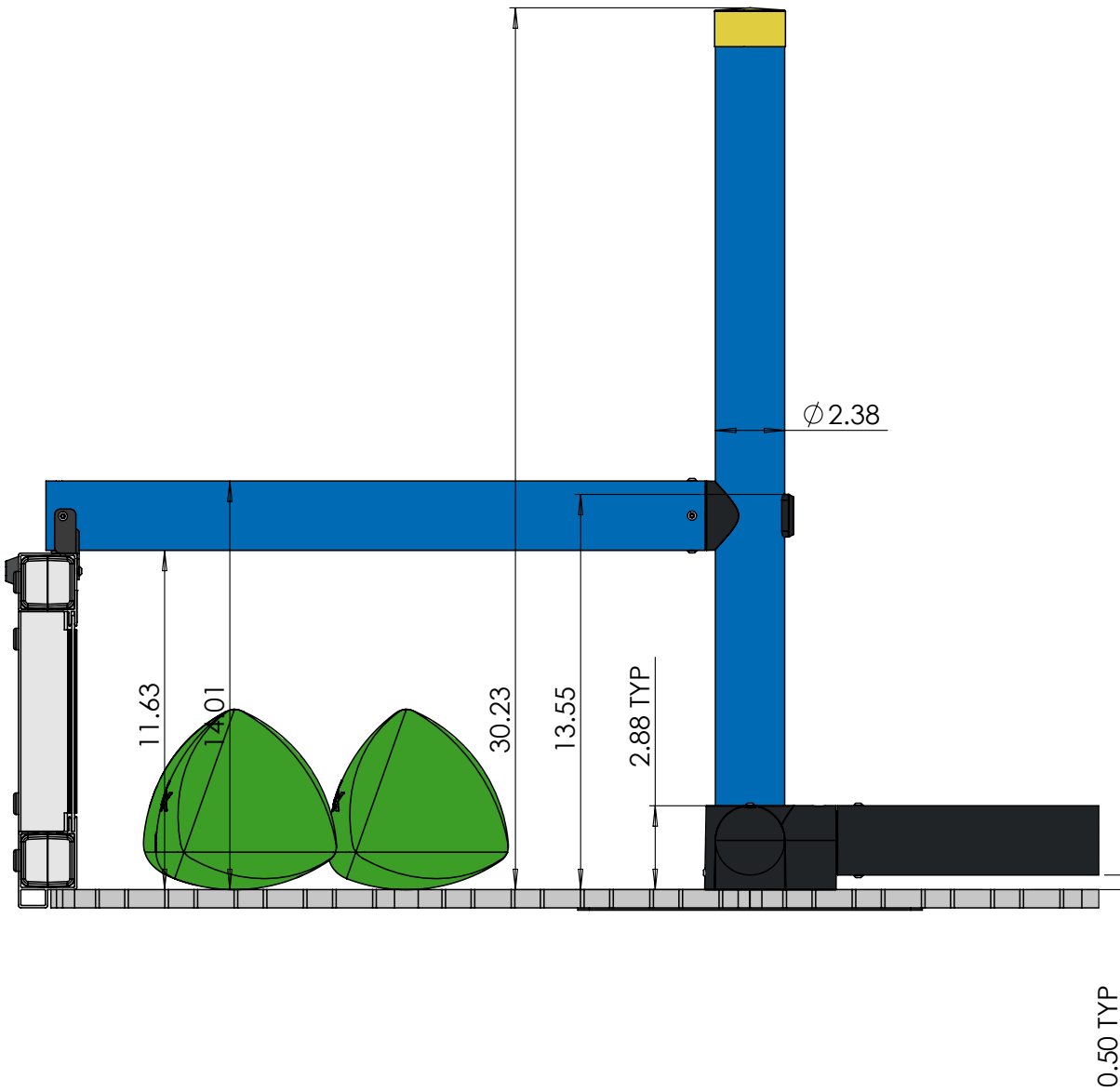

	Description 2023-2024 Game Specifications (5)	
	Dwg No 276-8354-000 Field Specifications	
	Competition VRC 2023-2024	Sheet 10 of 15
	Release 6/23/2023	ALL DIMENSIONS ARE IN INCHES.

WWW.VEXROBOTICS.COM

Note: The yellow Elevation Bar Cap was removed from VRC fields in version 3.0 of the Game Manual.

Load Zone Specs:

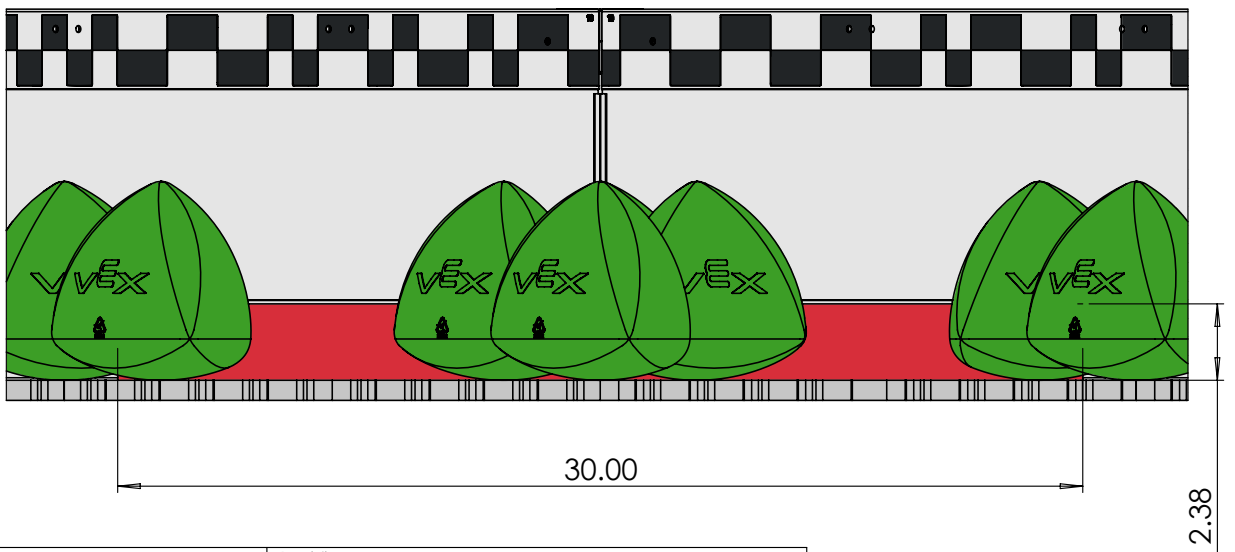
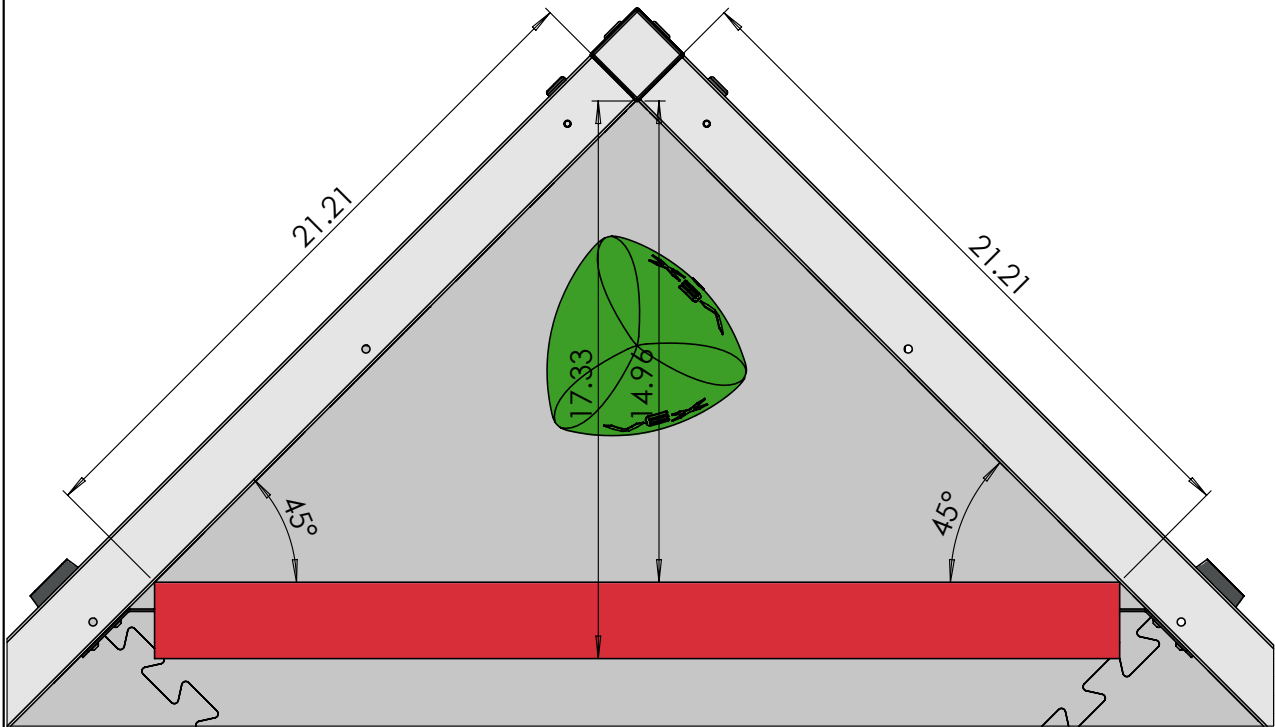

Description	2023-2024 Game Specifications (6)	
Dwg No	276-8354-000 Field Specifications	
Competition	VRC 2023-2024	Sheet 11 of 15
Release	6/23/2023	ALL DIMENSIONS ARE IN INCHES.

www.VEXROBOTICS.COM

Measurement Stick Specs:

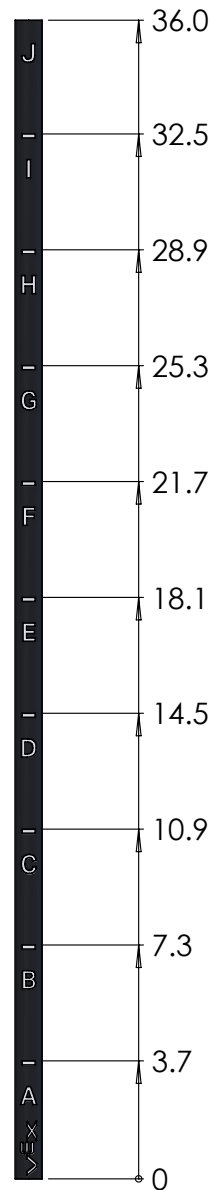

	Description 2023-2024 Game Specifications (7)	
	Dwg No 276-8354-000 Field Specifications	
	Competition VRC 2023-2024	Sheet 12 of 15
	Release 6/23/2023	ALL DIMENSIONS ARE IN INCHES.

www.VEXROBOTICS.COM

Field Reference Specs:

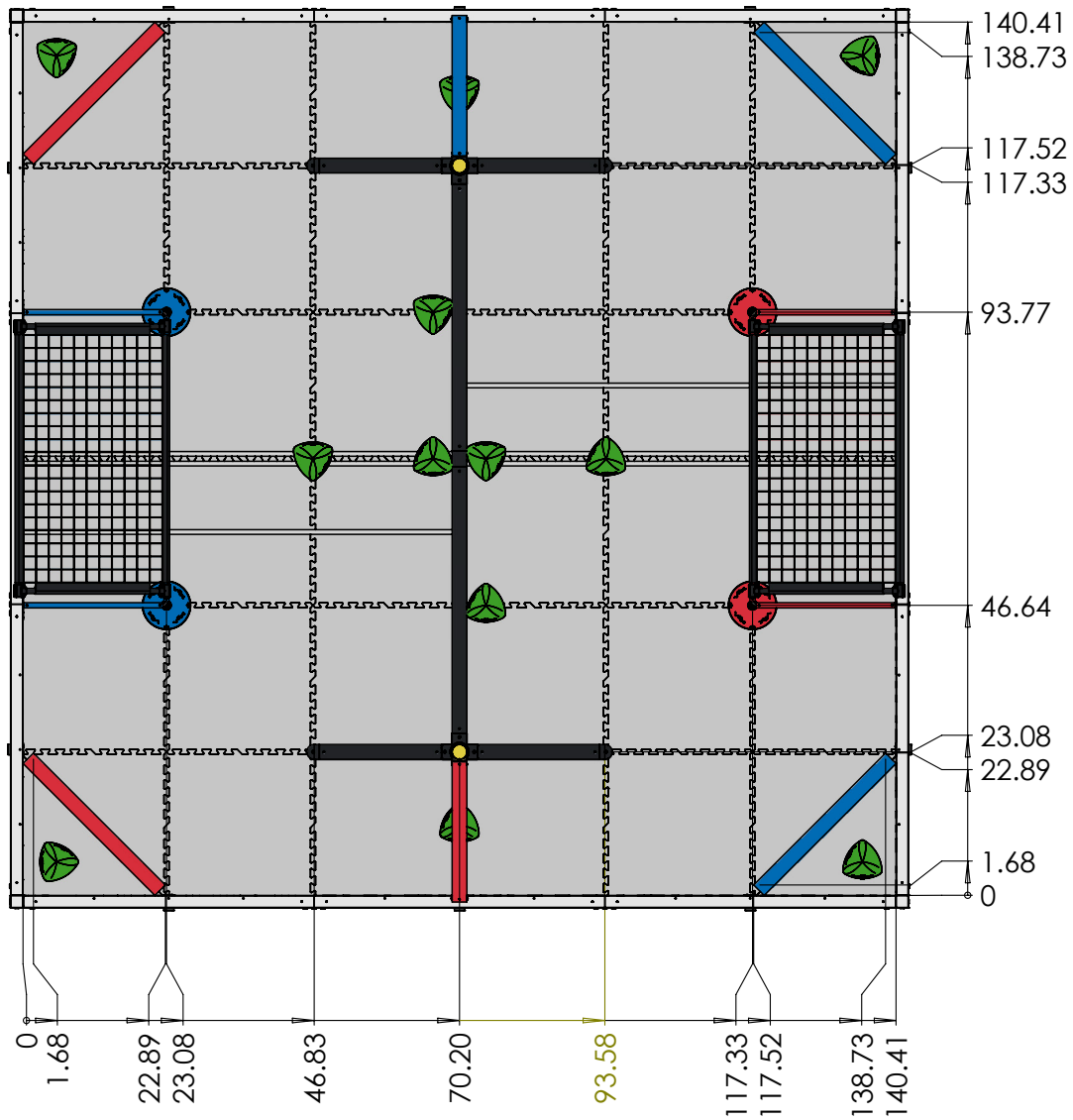

	Description 2023-2024 Game Specifications (8)	
	Dwg No 276-8354-000 Field Specifications	
	Competition VRC 2023-2024	Sheet 13 of 15
	Release 6/23/2023	ALL DIMENSIONS ARE IN INCHES.
		WWW.VEXROBOTICS.COM

Note: The yellow Elevation Bar Cap was removed from VRC fields in version 3.0 of the Game Manual.

Field Reference Specs:

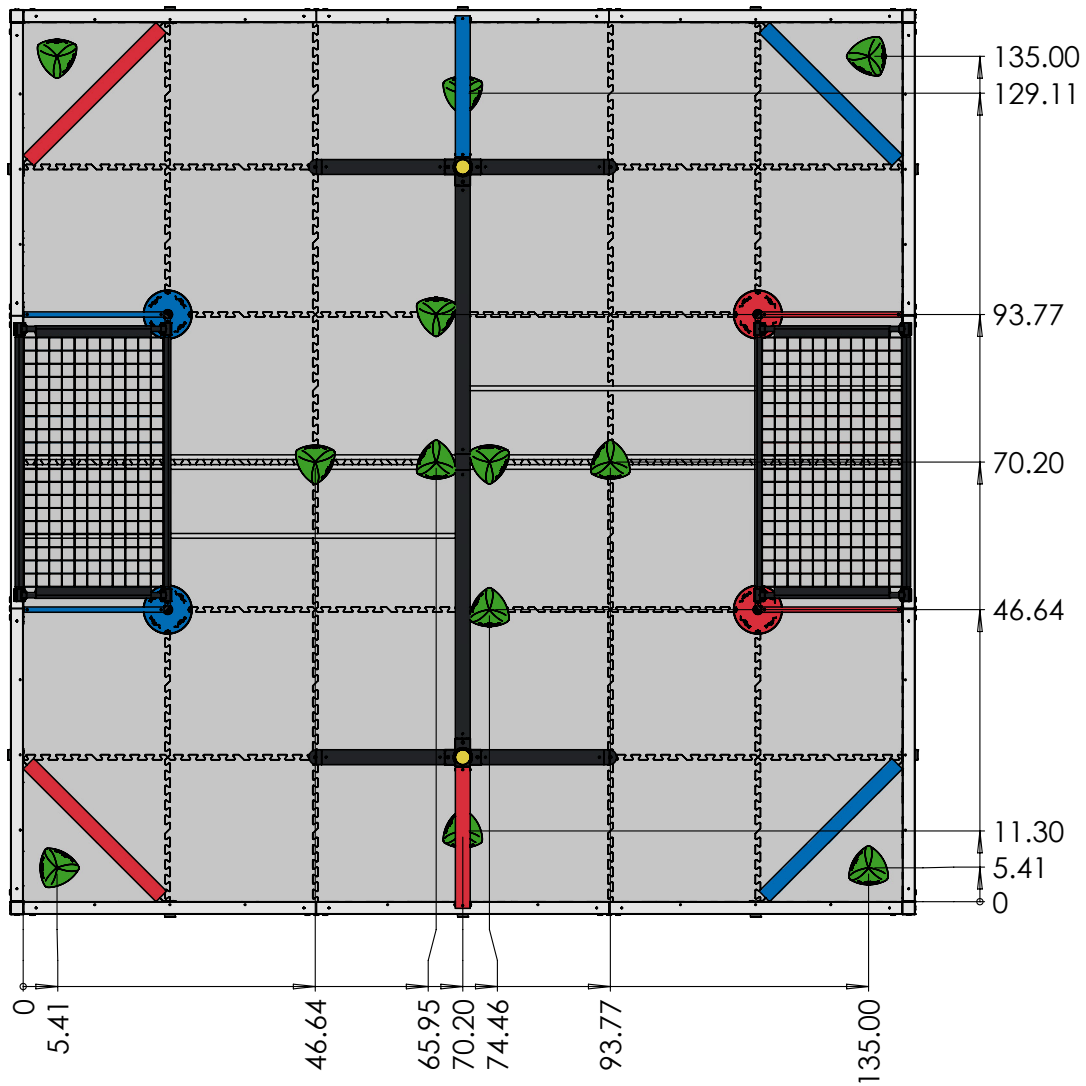

	Description 2023-2024 Game Specifications (9)	
	Dwg. No. 276-8354-000 Field Specifications	
	Competition VRC 2023-2024	Sheet 14 of 15
	Release 6/23/2023	ALL DIMENSIONS ARE IN INCHES. WWW.VEXROBOTICS.COM

Note: The yellow Elevation Bar Cap was removed from VRC fields in version 3.0 of the Game Manual.

Field Reference Specs Skills Layout:

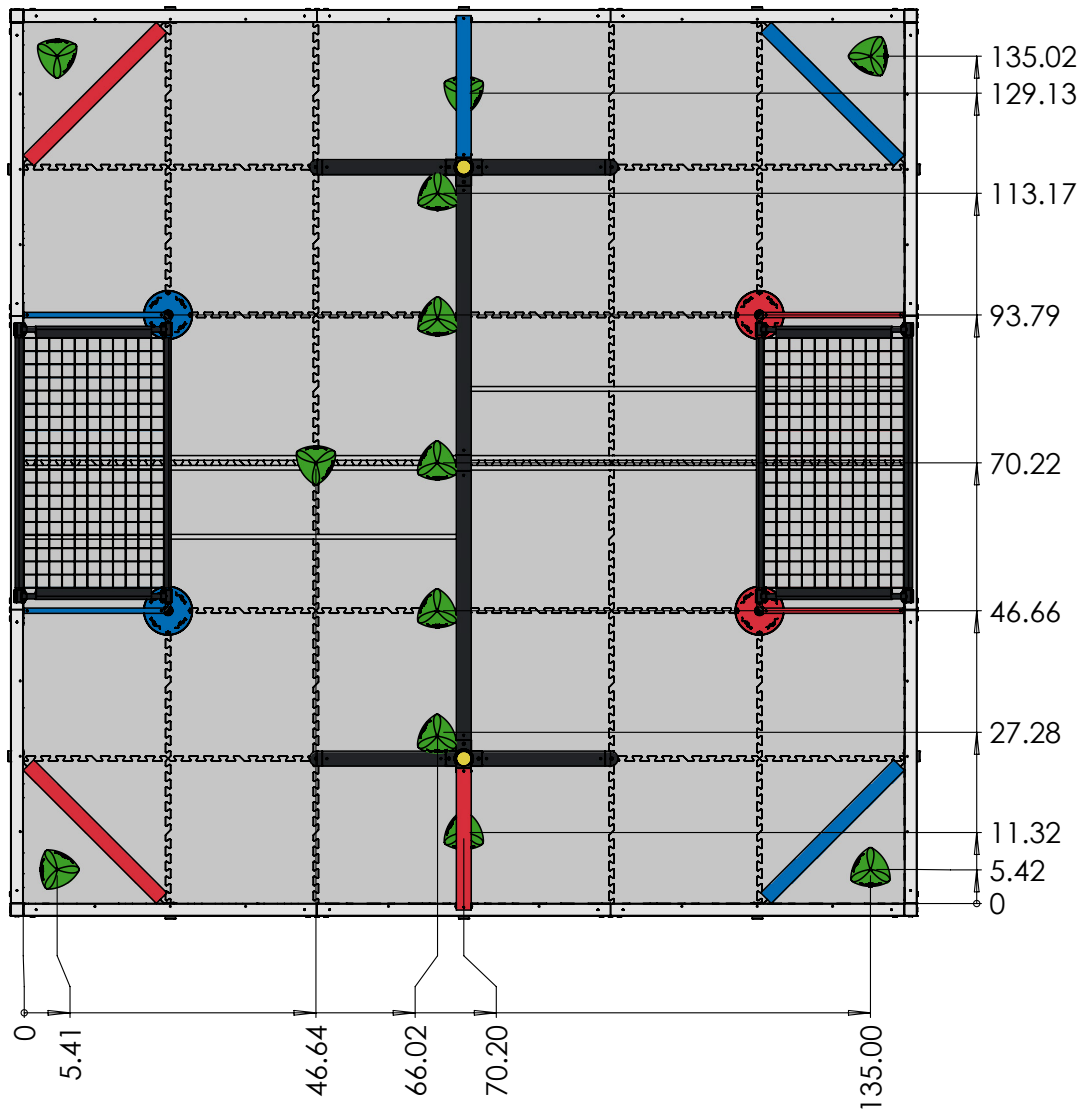

	Description 2023-2024 Game Specifications (10)	
	Dwg No 276-8354-000 Field Specifications	
	Competition VRC 2023-2024	Sheet 15 of 15
	Release 11/30/2023	ALL DIMENSIONS ARE IN INCHES.
		WWW.VEXROBOTICS.COM

Note: The yellow Elevation Bar Cap was removed from VRC fields in version 3.0 of the Game Manual.

Permitted Field Modifications

Problem: Mounting Plates are sliding around on a slick floor below the field

Solution: The metal mounting plates are prone to sliding around on slick floors and some events have reported their fields shifting throughout the day because of this. In an effort to help keep the metal plates from slipping on the floor (and potentially damaging it), placing a layer of Non-Slip Tape or Gaffer's Tape (or similar) between the metal plate and the floor to help keep the plates in place can be acceptable.



Problem: The Plastic Clip on the Net may become too loose around the PVC Pipes, even when tightened.

Solution: Add a small piece of tape or two inside of the Plastic Connector to help grip the PVC Pipe tightly.



Problem: After a large amount of gameplay, the sleeve of the net on the front PVC pipe of the goal can begin tearing.

Solution: Using Gaffer's Tape to fix any tears or frays on the fabric of the net sleeve is allowed. Please be sure to measure the goal after your modification and make appropriate adjustments to the height of the goal to ensure the gap between the tape and the foam tiles is within tolerance. Please use black tape if possible.



Problem: Field Elements may shift & begin tearing tiles under rough, prolonged gameplay.

Solution: Events may choose to add additional standoffs to the metal plates placed below the tiles. These additional standoffs will help to keep elements in place and mitigate the problem of field tiles tearing. If this modification is performed, please ensure that no standoffs sit proud of the field tiles.

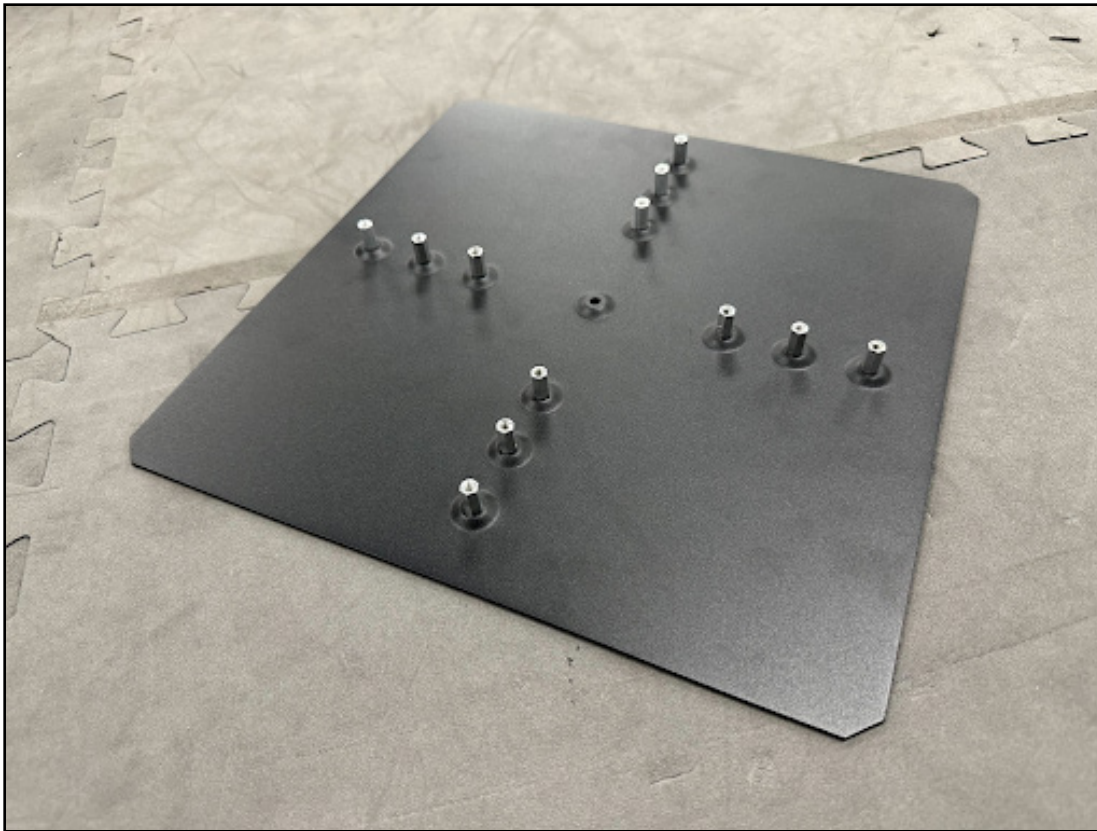

Note: Goals will be secured to the field risers at VEX Worlds 2024.



2023 - 2024

Appendix B - Robot Skills Challenge

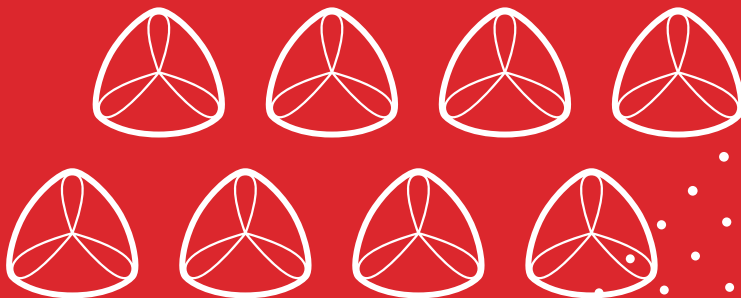

Appendix B - Robot Skills

Overview

This Appendix describes the Robot Skills Challenge rules for VEX Robotics Competition Over Under. All rules from "The Game" section of the manual apply to the Robot Skills Challenge, unless otherwise specified in this Appendix.

Robot Skills Challenge Description

In this challenge, *Teams* will compete in sixty-second (1:00) long *Matches* in an effort to score as many points as possible. These *Matches* consist of *Driving Skills Matches*, which are entirely driver controlled, and *Autonomous Coding Skills Matches*, which are autonomous with limited human interaction. *Teams* will be ranked based on their combined score in the two types of *Matches*.

The Robot Skills Challenge playing field is set up almost exactly the same as a Head-to-Head VEX Robotics Competition Over Under *Match*, with the following modifications:

- In *Autonomous Coding Skills Matches*, the VEX GPS code strip must be installed on the field
- The two (2) Blue *Alliance Triball Preloads* will not be used
- All of the forty-four (44) Match Load *Triballs* will be located in the red *Alliance Station*
- The pre-match placement of the twelve (12) *Triballs* on the field will be in non-scored positions as shown below

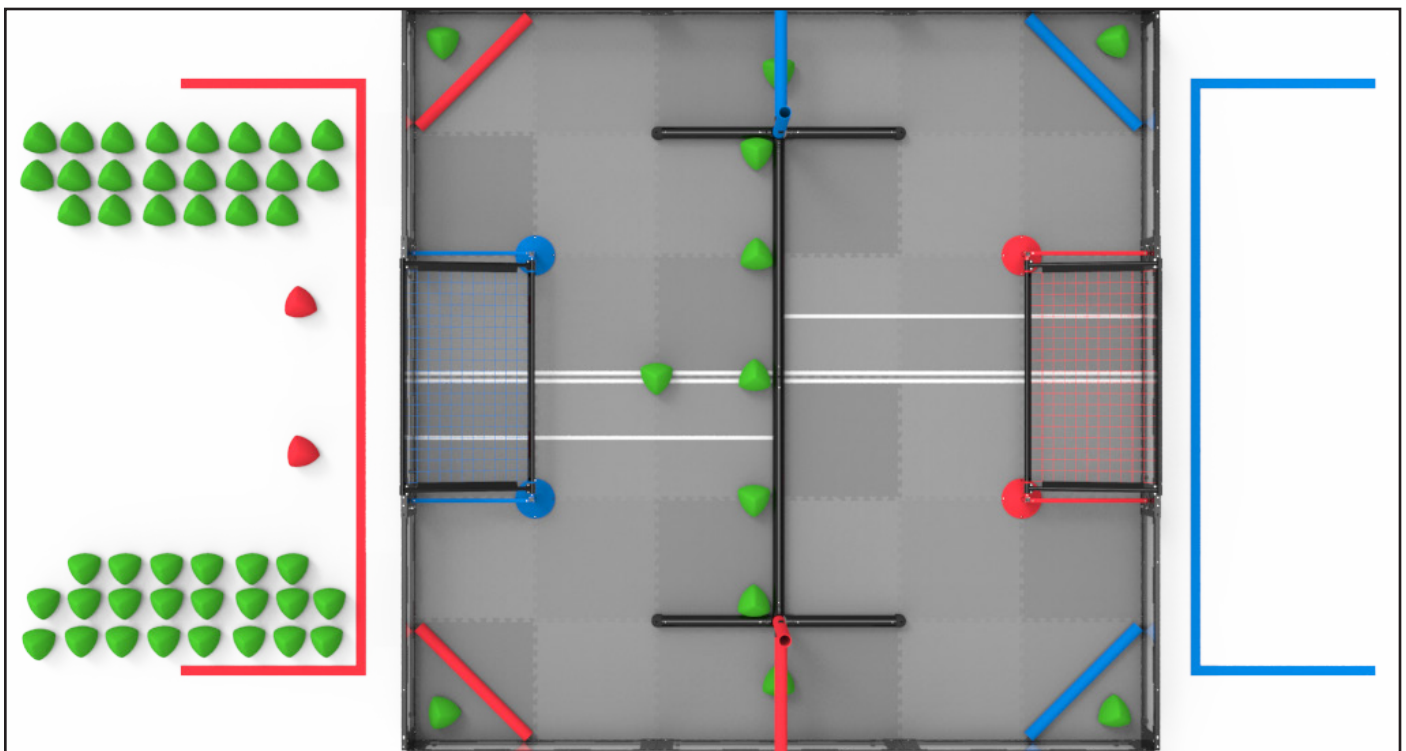

Robot Skills Challenge at a Standard Qualifying Tournament

- The Robot Skills Challenge is an optional event for all *Teams*. *Teams* who do not compete will not be penalized in the main tournament. However, participation in the Robot Skills Challenge may impact eligibility for judged awards at the event.
- *Teams* may play *Robot Skills Matches* on a “first come, first served” basis, or by a pre-scheduled method determined by the *Event Partner*.
- *Teams* will be given the opportunity to play exactly three (3) *Autonomous Coding Skills Matches* and three (3) *Driving Skills Matches*. *Teams* should be aware of when the Robot Skills fields are open so that they do not miss their opportunity. For example, if a *Team* waits until five minutes before the Robot Skills fields close, then they have not used the opportunity given to them and will not be able to compete in all six matches.
- Further details regarding Skills-Only Event logistics can be found in the REC Foundation Qualification Criteria document.

Robot Skills Challenge Definitions

All definitions from “The Game” section of the manual apply to the Robot Skills Challenge, unless otherwise specified.

Driving Skills Match – A *Driving Skills Match* consists of a sixty-second (1:00) *Driver Controlled Period*. There is no *Autonomous Period*. *Teams* can elect to end their run early if they wish to record a *Skills Stop Time*.

Autonomous Coding Skills Match – An *Autonomous Coding Skills Match* consists of a sixty-second (1:00) *Autonomous Period*. There is no *Driver Controlled Period*. *Teams* can elect to end their run early if they wish to record a *Skills Stop Time*.

Robot Skills Match – A *Driving Skills Match* or *Autonomous Coding Skills Match*.

Skills Stop Time – The time remaining in a *Robot Skills Match* when a *Team* ends the *Match* early.

- If a *Team* does not end the *Match* early, they receive a default *Skills Stop Time* of 0.
- The moment when the *Match* ends early is defined as the moment when the *Robot* is “disabled” by the field control system. See the “*Skills Stop Time*” section for more details.
- If a V5 Robot Brain or Tournament Manager display is being used for field control, then the *Skills Stop Time* is the time shown on the display when the *Match* is ended early (i.e. in 1-second increments).
- If a VEXnet Competition Switch is being used for field control, in conjunction with a manual timer that counts down to 0 with greater accuracy than 1-second increments, then the time shown on the timer should be rounded up to the nearest second. For example, if the *Robot* is disabled and the timer shows 25.2 seconds, then the *Skills Stop Time* should be recorded as 26.

Robot Skills Challenge Rules

<RSC1> All rules from “The Game” section of the manual apply to the Robot Skills Challenge, unless otherwise specified.

Violation Note: In the Robot Skills Challenge, the standard definition of Match Affecting does not apply, since there is no winner and loser. When evaluating whether a rule Violation should be classified as a Major or Minor Violation in the context of this criteria, the term “score affecting” can be substituted for “Match Affecting”. A Violation is considered “score affecting” if it resulted in a net increase of that Team’s score at the end of the Match.

<RSC2> Robots may start the Robot Skills Match on any legal Starting Tiles for either Alliance.

- a. All Drive Team Members must be in the red Alliance Station for the duration of the Match.
- b. Robots must meet all of the criteria listed in rule <SG1>.
- c. Teams may use the two (2) red Alliance Preloads as follows:
 - i. One Preload must be placed per <SG4>.
 - ii. The second red Alliance Triball may be placed in any non-scored position in the Blue Offensive Zone and not touching the Robot, or may be used as a Match Load per <SG6> and <RSC3>.
- d. The two (2) blue Alliance Triballs are not used in Robot Skills Matches.
- e. The Note in <SG1> applies to all Match Load Zone Triballs, regardless of which Starting Tiles are used.

<RSC3> Teams may utilize the forty-four (44) Match Load Triballs within the guidelines set forth by <SG5>.

- a. Match Load Triballs begin the match in the red Alliance Station.
- b. Match Load Triballs must be introduced from the red Alliance Station per <SG6>.
- c. Match Load Triballs may be introduced during Autonomous Coding Skills Matches (i.e. the “Note” in rule <SG6> does not apply). Using sensors to detect legally-entered Match Load Triballs is not considered a violation of rule <G11>.

<RSC4> In Robot Skills Matches, Teams play as if they are on the red Alliance.

- a. Robots may freely move about the field after the start of the Match.
- b. Robots may utilize either Elevation Bar.

- c. Non-alliance specific *Triballs* may be scored in the red *Offensive Zone* and the red *Goal* per <SC3> and <SC4>.
- d. Red *Alliance Triballs* may be scored in the red *Offensive Zone*, the red *Goal*, or the blue *Goal* per <SC5>. Red *Alliance Triballs* cannot be Scored in the blue *Offensive Zone*.
- e. Rule <SG8> does not apply in *Robot Skills Matches* (i.e., *Robots* may freely break the plane of either *Goal* at any time).

<RSC5> Elevation points are awarded based on the *Elevation Tier* achieved by the *Robot* at the end of the *Match*. A *Robot's Elevation Tier* is measured by placing the *Height Guide* vertically next to an *Elevated Robot* and determining which letter-labeled segment of the *Height Guide* the lowest point of the *Robot* falls within. For *Robot Skills Matches*, tiers are assigned based on the following:

- Top Tier: H or higher (20 Points)
- 2nd Tier: E-G (15 Points)
- 3rd Tier: B-D (10 Points)
- 4th Tier: A (5 Points)

<RSC6> There is no requirement that Skills Challenge fields have the same consistent modifications as the Head-to-Head fields. For example, there is no requirement that all Skills Challenge fields are elevated to the same height as Head-to-Head fields. However, all Skills Challenge fields at a single event must use the same type of field control and field perimeter, as described in rules <T23> and <T24>.

It is strongly recommended/preferred that all Skills Challenge fields are consistent with each other, but this may not be the case in extreme circumstances.

In order to use non-conforming Head-to-Head fields for Skills Challenge runs (e.g. during lunch), the following steps should be taken:

- *Teams* must be informed that the Head-to-Head fields may have some differences from the Skills Challenge Fields (e.g., they might not have GPS strips).
- *Teams* must be given an opportunity to select which type of field they want to use, i.e. they cannot be required to use the Head-to-Head field for any Skills Challenge run.

<RSC7> *Triballs* which come to rest on top of the red *Goal* may not be retrieved by a *Drive Team Member* or Referee during the *Match*. *Triballs* which come to rest on top of the blue *Goal* may be retrieved by a *Drive Team Member* per <SG3>.

Robot Skills Challenge Scoring

Points are awarded according to the same scoring rules as Head-to-Head Matches, unless otherwise noted above. A *Team's* score at the end of a *Robot Skills Match* is calculated by combining the scores that would have been awarded to the red *Alliance*.

Skills Stop Time

If a *Team* wishes to end their *Robot Skills Match* early, they may elect to record a *Skills Stop Time*. This is used as a tiebreaker for Robot Skills Challenge rankings. A *Skills Stop Time* does not affect a *Team's* score for a given *Robot Skills Match*.

- *Teams* who intend to attempt a *Skills Stop Time* must "opt-in" by verbally confirming with the *Scorekeeper Referee* prior to the *Robot Skills Match*. If no notification is given prior to the start of the *Match*, then the *Team* forfeits their option to record a *Skills Stop Time* for that *Match*.
 - This conversation should include informing the *Scorekeeper Referee* which *Drive Team Member* will signal the stop. The *Match* may only be ended early by a *Drive Team Member* for that *Match*.
 - If a *Team* runs multiple *Robot Skills Matches* in a row, they must reconfirm their *Skills Stop Time* choice with the *Scorekeeper Referee* prior to each *Match*.
 - Any questions regarding a *Skills Stop Time* should be reviewed and settled immediately following the *Match*. <T1> and <T3> apply to *Robot Skills Matches*.

- If the event is utilizing a V5 Robot Brain or the TM Mobile app for Robot Skills Challenge field control, a *Drive Team Member* may elect to start and stop their own *Robot Skills Matches*.
 - This V5 Robot Brain or other device running the TM Mobile app will be used to start the *Robot Skills Matches* (i.e., "enable" the *Robot*), end the *Robot Skills Match* (i.e., "disable" the *Robot*), and display the official *Skills Stop Time* to be recorded.
 - This V5 Robot Brain must be running the official field control user program.
 - For more information regarding the use of a V5 Robot Brain for Robot Skills Challenge field control, and to download the official field control user program, [visit this VEX Knowledge Base article](#).
 - For more information regarding the use of TM Mobile for field control, [see the Tournament Manager documentation](#).

- At events which do not have a V5 Robot Brain or the TM Mobile App available for Robot Skills Challenge field control, *Drive Team Members* and field staff must agree prior to the *Match* on the signal that will be used to end the *Match* early.
 - As noted in the definition of *Skills Stop Time*, the moment when the *Match* ends early is defined as the moment when the *Robot* is "disabled" by the field control system.
 - The agreed-upon signal must be both verbal and visual, such as *Drive Team Members* crossing their arms in an "X" or placing their V5 Controller(s) on the ground.
 - The signal must be given by a *Drive Team Member* who is standing in the *Alliance Station*.
 - It is recommended that *Drive Team Members* also provide verbal notice that they are approaching their *Skills Stop Time*, such as by counting out "3-2-1-stop."

- It is at the *Event Partner's* discretion which method will be used to record *Skills Stop Times* at a given event. The chosen method must be communicated prior to the event (such as during a Drivers' meeting), and made equally available to all *Teams*.
 - If an event intends to use a manual timekeeping method, a *Team* may not bring their own V5 Robot Brain just for use during their own *Robot Skills Match*.
 - If an event intends to utilize a V5 Robot Brain, all *Teams* must use the same V5 Robot Brain for all *Robot Skills Matches* on a given field.
 - If an event is using multiple fields for *Robot Skills Matches*, the same method must be used at all fields, as described in rule <RSC6>. Multiple V5 Robot Brains may be used as needed (e.g., a "Field 1 Brain" and a "Field 2 Brain").
 - The default "Drive" program accessed from a V5 Controller is intended for practice only, and may not be used for an official *Robot Skills Match*.

Robot Skills Challenge Ranking at Events

For each *Robot Skills Match*, *Teams* are awarded a score as described in the Robot Skills Challenge Scoring section, and an optional *Skills Stop Time* as described in the *Skills Stop Time* section. *Teams* will be ranked based on the following tiebreakers:

1. Sum of highest *Autonomous Coding Skills Match* score and highest *Driving Skills Match* score.
2. Highest *Autonomous Coding Skills Match* score.
3. Second-highest *Autonomous Coding Skills Match* score.
4. Second-highest *Driving Skills Match* score.
5. Highest sum of *Skills Stop Times* from a *Team's* highest *Autonomous Coding Skills Match* and highest *Driving Skills Match* (i.e., the *Matches* in point 1).
6. Highest *Skills Stop Time* from a *Team's* highest *Autonomous Coding Skills Match* (i.e., the *Match* in point 2).
7. Third-highest *Autonomous Coding Skills Match* score.
8. Third-highest *Driving Skills Match* score.
9. If a tie cannot be broken after all above criteria, then the following ordered criteria will be used to determine which *Team* had the "best" *Autonomous Coding Skills Match*:
 - a. Number of *Triballs Scored* in *Goals*.
 - b. Number of *Triballs Scored* in the *Red Offensive Zone*.
 - c. *Elevation Tier* points score

- If the tie still isn't broken, the same process in Step 9 will be applied to each *Team's* best *Driving Skills Match*.
- If the tie still isn't broken, events may choose to allow *Teams* to have one more deciding *Driving Skills Match*, to be ranked according to the standard criteria above, or declare both *Teams* the Robot Skills Challenge Winner.

Robot Skills Challenge Ranking Globally

Teams will be ranked globally based on their Robot Skills scores from Tournaments and Leagues that upload results to robotevents.com, according to the following tiebreakers:

1. Highest Robot Skills score (combined *Autonomous Coding Skills Match* and *Driving Skills Match* Score from a single event).
2. Highest *Autonomous Coding Skills Match* score (from any event).
3. Highest sum of *Skills Stop Times* from the *Robot Skills Matches* used for point 1.
4. Highest *Skills Stop Time* from the *Autonomous Coding Skills Match* used for point 2.
5. Highest *Driving Skills Match* score (from any event).
6. Highest *Skills Stop Time* from the *Driving Skills Match* score used for point 5.
7. Earliest posting of the Highest *Autonomous Coding Skills Match* score.
 - a. The first *Team* to post a score ranks ahead of other *Teams* that post the same score at a later time, all else being equal.
8. Earliest posting of the Highest *Driving Skills Match* score.
 - a. The first *Team* to post a score ranks ahead of other *Teams* that post the same score at a later time, all else being equal.

League Events

At league events in which *Teams* may submit Robot Skills Challenge scores across multiple days / sessions, the Robot Skills scores (combined highest *Autonomous Coding Skills Match* and *Driving Skills Match* scores) used for rankings will be calculated from *Matches* within the same session.

For example, consider the following scores for a hypothetical *Team* across two league event sessions:

	<i>Autonomous Coding Skills Match</i>	<i>Driving Skills Match</i>	Robot Skills Score
Session 1	100	100	200
Session 2	150	40	190

This *Team* would have a Robot Skills score of 200 for this event, and their scores from Session 1 would be used for the Event and Global tiebreakers listed in the above two sections.



vEX[®]
ROBOTICS
COMPETITION
OVER UNDER

2023 - 2024
Appendix C - VEX U

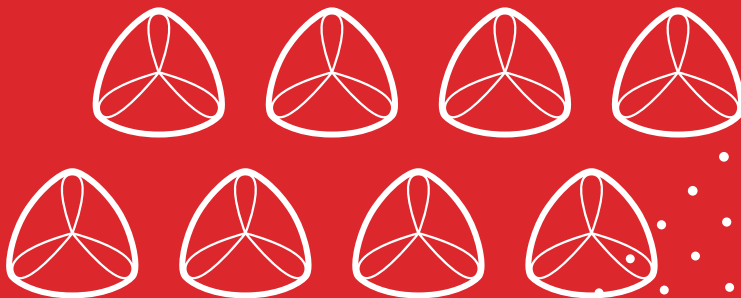

Appendix C - VEX U

Introduction

While many colleges and universities already use the VEX V5 system in their academic classes, many more have extensive manufacturing capabilities beyond the standard “VEX metal” library. Fabrication techniques like machining and 3D printing are more common than ever in collegiate engineering programs, and we can’t wait to see what VEX U *Teams* from around the world are able to create under these more advanced rules.

As in past years, the season will include a culminating VEX U event at the VEX Robotics World Championship, along with regional tournaments across the world. Participating schools will get the chance to prove their abilities in front of thousands of future engineers and show off what truly makes their school remarkable. VEX U is the perfect project-based supplement to many university level engineering programs, and will give students the unique opportunity to demonstrate their real-world skills to potential employers (such as VEX competition sponsors).

Event Information

Several of the University partners participating in VEX U will be holding tournament events in addition to the capstone competition at the 2024 VEX Robotics World Championship. Refer to <https://www.robotevents.com/> for event details, pricing, and registration info for VEX U events.

Game, Robot, and Tournament Rules

VEX U uses the VEX Robotics Competition Over Under field with no modifications. Anyone that has a VEX Robotics Competition Over Under field can use it for a VEX U event or *Team*. Please consult the VEX Robotics Competition Over Under Game Manual for the basic set of competition rules and details.

All of the standard Game, Robot, & Tournament rules apply, except for the modifications listed in this document. In the event of a rules conflict, the rules listed in this document and rulings on the VEX U Q&A take precedence.

VEX U Definitions

Additional Electronics - Any sensor, processor, or other electronic component used in Robot construction, and connected to the V5 Robot Brain, that is not sold by VEX Robotics. Examples could include commercially-available devices (e.g., Raspberry Pi) or custom devices designed and fabricated by the Team. See <VUR10> for more details.

Fabricated Part - Any component used in Robot construction that is fabricated by Team members. See <VUR3>, <VUR4>, and <VUR5> for more details.

Raw Stock - Stock materials purchased from third-party vendors that may be used to create Fabricated Parts. See <VUR4>.

Rule Modifications: Field Setup

The VEX U playing field is set up almost exactly the same as a Head-to-Head VEX Robotics Competition Over Under Match, with the following modifications as shown in Figure 41.

- The VEX GPS code strip must be installed on the field
- Twelve (12) green *Triballs* start on the field, as shown in Figure 41
- All four (4) *Alliance Triballs* start on the field in the *Match Load Zones*, as shown in Figure 41
- *Teams* use one (1) green *Triball* per *Robot* as a *Preload*
- Each *Team* has twenty (20) *Triballs* that are used as *Match Loads*, ten (10) of which may be introduced during the *Autonomous Period*
- The yellow *Elevation Bar Caps* must be installed on the field.

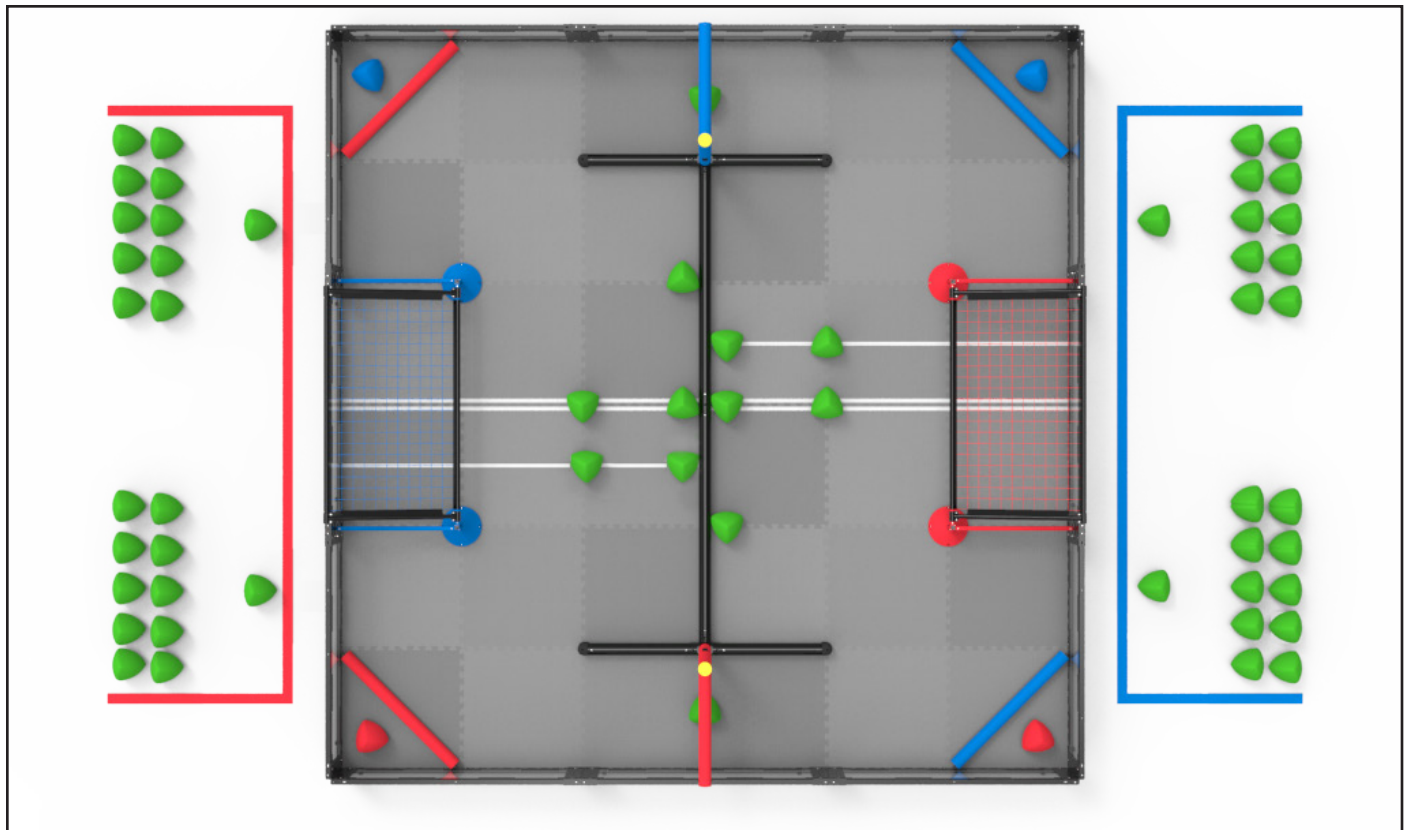

Figure 41: The VEX U Field Setup

Rule Modifications: Game

<VUG1> Different Starting Tiles. All criteria of rule <SG1> apply as written. However, the locations of each *Team's Starting Tiles* are modified as shown in Figure 42. VEX U *Teams* may adjust the starting positions of both of their *Alliance Triballs* as described in the note following rule <SG1> (i.e., the red *Alliance* may reposition the red *Triballs*, and the blue *Alliance* may reposition the blue *Triballs*).

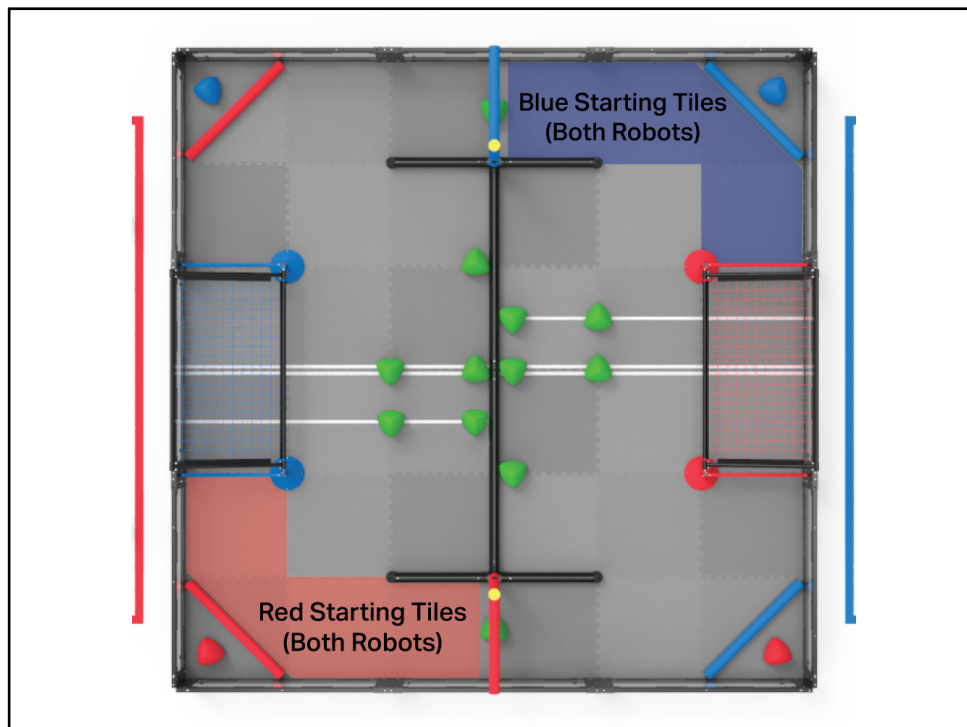

Figure 42: VEX U Starting Positions

<VUG2> Different Preloads. All criteria of rule <SG4> apply as written. However, the *Triballs* that are used as *Preloads* are standard (green) *Triballs*. *Alliance Triballs* begin in the *Match Load Zones*, as shown in Figure 42.

<VUG3> Different Autonomous zones. During the *Autonomous Period*, *Robots* may not contact foam tiles, *Triballs*, or *Field Elements* on the opposing *Team's* side of the *Neutral Zones*. However, *Robots* are free to move between *Offensive Zones* at any time. All other portions of rule <SG9> apply as written.

<VUG4> Different Match Load introductions. Point "1" in rule <SG6> is the only permitted method of *Match Load* introduction. *Match Loads* must be placed directly onto the *Match Load Zone*, and released from the *Drive Team Member's* hand, before being contacted by that *Team's Robot*.

The intent of <VUG4> is to emphasize the concept of “Robots play the game, not humans” to its full extent. This means encouraging designs which do not require significant human assistance to retrieve Match Loads. Examples of prohibited behaviors include “rolling” or “bouncing” Triballs towards a Robot. [Please see this Q&A for more information.](#)

Significant Q&As

- 1574 - [Placing a Triball point-down and allowing it to tip over is legal](#)
- 1857 - [Don't roll Match Loads, especially not into Robots; Robots should do the work, not well-practiced humans; don't put a Triball into/onto a Robot mechanism](#)
- 1942 - [Leaning a Match Load against the Match Load Bar or in a corner of the Match Load Zone is legal](#)

<VUG5> Different Match Load availability. Up to ten (10) Match Loads may be introduced during the *Autonomous Period*. Any Match Loads that are not introduced during the *Autonomous Period* may be used during the *Driver Controlled Period*. During the *Autonomous Period* of a Head-to-Head Match, each *Alliance* may only use the *Match Load Zone* that is adjacent to that *Alliance's Robot Starting Tiles*. This restriction does not apply to *Autonomous Coding Skills Matches* or *Driver Controlled Periods*.

Note: Match Loads may not be introduced during the time between the Autonomous Period and Driver Controlled Period. If both Teams agree to end the Autonomous Period early, as described in <VUT4>, this also signals a pause on Match Load introductions until the Driver Controlled Period begins.

<VUG6> Different Autonomous Win Point. This rule supersedes rule <SC7>. An *Autonomous Win Point* is awarded to any *Team* that has completed the following tasks at the end of the *Autonomous Period*:

- Scored both of their *Alliance Triballs* in *Goals*.
- Ended the *Autonomous Period* with both *Robots* contacting their own *Elevation Bar*
- Not violated any other rules.

Rule Modifications: Tournament

<VUT1> Instead of a 2-Team *Alliance* format, VEX U Matches will be played 1-Team vs. 1-Team. Each *Team* will use two (2) *Robots* in each *Match*.

- Teams* are allowed to build as many *Robots* as they would like, but only two (2)—one of each size as described in <VUR1>—may be brought from the pit to the playing field for any *Match*.
- All *Robots* must pass inspection before they are allowed to compete.

<VUT2> *Qualification Matches* will be conducted in the same manner as in a VRC tournament, but in the revised 1v1 format described in <VUT1>.

<VUT3> *Elimination Matches* will be conducted in the same manner as in a VRC tournament, but without an *Alliance Selection*. At the end of the competition, one *Team* will emerge as the tournament champion.

<VUT4> The *Autonomous Period* at the beginning of each Head-to-Head *Match* will be 45 seconds (0:45).

- a. Human interaction with *Robots* during the *Autonomous Period* is strictly prohibited.
 - i. Using sensors to detect legally-entered Match Load *Triballs* is not considered a *Violation* of this rule.
- b. If both *Teams* complete their routines before 45 seconds have elapsed, they have the option to signal that they wish to end the *Autonomous Period* early. Both *Teams* and the *Head Referee* must all agree on the "early stop." This is not a requirement, and the option must have been established for all *Teams* at the event, such as during the Driver's meeting.

<VUT5> The *Driver Controlled Period* is shortened to 75 seconds (1:15) and immediately follows the *Autonomous Period*.

<VUT6> Each *Robot* is allowed up to three (3) *Drive Team Members* in the *Alliance Station* during a *Match*, as modified from <G8>.

<VUT7> VEX U *Student* eligibility.

- a. All VEX U *Team* members MUST be matriculated in a post-secondary school OR have earned a post-secondary education diploma, certificate, or other equivalent during the six (6) months preceding the VEX Robotics World Championship. The intent of this rule is to permit *Students* graduating mid-year to still be able to finish their competition season.
- b. Professionals not enrolled in post-secondary education are not eligible to participate on a VEX U *Team*.
- c. *Students* who are dual-enrolled in both a secondary school and in post-secondary courses are not eligible to participate on a VEX U *Team*.
- d. VEX U *Team* members may only be on exactly one (1) VEX U *Team* for the season. See <G4>.

Rule Modifications: Robot Skills Challenge

All rules apply from VRC Appendix B: Robot Skills Challenge, with no modifications other than those noted below. Teams are permitted to use both Robots in their VEX U Robot Skills Challenge Matches, per <VUT1>, <VUT6>, and <VUR1>.

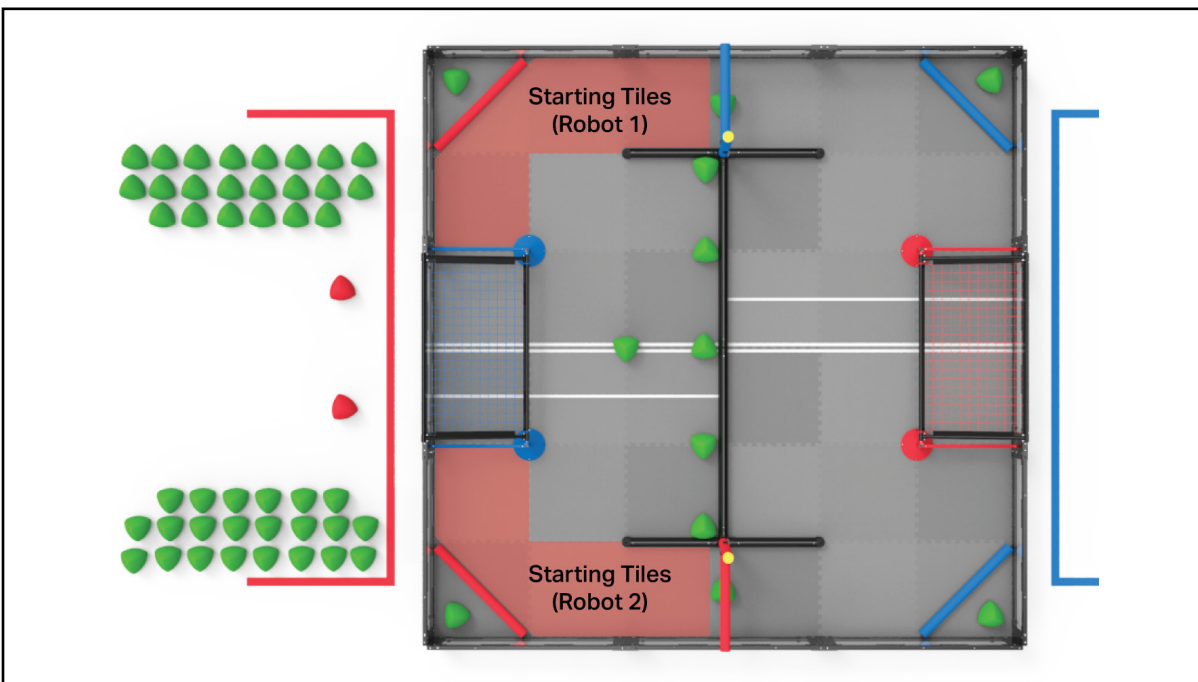

Figure 42: VEX U Starting Skills Layout

<VURS1> One Robot must start the Robot Skills Match in each set of Starting Tiles, as shown in Figure 42. If only one Robot is being used, it may start in either set of Starting Tiles. All other portions of rule <SG1> apply.

<VURS2> The field is set up the same as a standard Robot Skills Match. However, the forty-four (44) Match Load Triballs are split into two sets of twenty-two (22) as shown in Figure 42, that may only be introduced via their corresponding Match Load Zone. Other than the exceptions noted in rule <SG3>, no Match Load Zone should receive more than twenty-two (22) Match Loads.

Note: Rule <VUG4> still applies to Robot Skills Matches. Rule <RSC3c> also applies to Autonomous Coding Skills Matches.

<VURS3> The Elevation Tier scoring listed in rule <RSC5> is used for both Robots. For example, if both Robots reach Elevation Tier B, then the Team will receive 20 total points.

Rule Modifications: Robot

<VUR1> Teams may use **two (2) Robots** in each Match.

- a. All Robots may only be built from the following materials:
 - i. Official VEX Robotics products (see <VUR2> .
 - ii. Fabricated Parts made by the Team (see <VUR3> through <VUR7>).
 - iii. Commercially-available springs, fasteners and bearings (see <VUR8>, <VUR9>, and <VUR14>).
 - iv. A legal electronics system (see <VUR10> and <VUR11>).
 - v. Any legal Additional Electronics (see <VUR12>).
 - vi. A legal pneumatics system (see <VUR13>).
- b. One Robot must be smaller than 24" x 24" x 24" at the start of the Match.
- c. One Robot must be smaller than 15" x 15" x 15" at the start of the Match.

Note: <SG2> applies as written to both Robots.

<VUR2> Teams may use **any official VEX Robotics products**, other than the exceptions listed in the tables below, to construct their Robot. This includes those from the VEXpro, VEX EXP, VEX IQ, VEX GO, VEX 123, VEX CTE, and VEX Robotics by HEXBUG* product lines. To determine if a product is "official" or not, refer to www.vexrobotics.com. Rule <R15> applies, and most modifications to non-electrical components are allowed.

SKU	Description
217-8080	Talon SRX
217-9191	Victor SPX
217-9090	Victor SP
217-4243	Pneumatic Control Module
217-4244	Power Distribution Panel
217-4245	Voltage Regulator Module

SKU	Description
217-4347	775pro
217-2000	CIM Motor
217-3371	Mini CIM Motor
217-3351	BAG Motor
217-6515	Falcon 500

This rule takes precedence over all other rules regarding *Raw Stock* and/or *Fabricated Parts*, such as <VUR5>.

** The HEXBUG brand is a registered trademark belonging to Spin Master Corp*

<VUR3> **Fabricated Parts** may be made by applying the following manufacturing processes to legal *Raw Stock*:

- a. Additive manufacturing processes, such as 3D printing.
- b. Subtractive manufacturing processes, such as cutting, drilling, routing, or machining.
- c. Bending, such as sheet metal braking or thermoforming.
- d. Attaching materials to one another, such as welding or chemically bonding (e.g., epoxy).
- e. Molding of non-metals, such as injecting polyurethane into a 3D printed mold.

<VUR4> *Fabricated Parts* must be made from legal **Raw Stock**. To be considered *Raw Stock*, the material must be purchased in one of the following forms before undergoing the fabrication processes listed in <VUR3>:

	Type	Shape / Profile	Examples
1	Sheet	Flat Plane	<ul style="list-style-type: none"> Sheet metal 1/8" polycarbonate sheet Plywood
2	Solid Billet	"Thick" rectangular beam / block	<ul style="list-style-type: none"> 4" x 4" x 6" solid aluminum billet 2" x 2" x 2" acetal block
3	Solid Bar	"Thin" rectangular beam	<ul style="list-style-type: none"> 2x4 wood planks 1/4" x 3" aluminum bars
4	Hollow Bar	Hollow rectangular beam	<ul style="list-style-type: none"> 1" x 1", 1/32" wall aluminum box tube
5	Solid Rod	Cylinder	<ul style="list-style-type: none"> 1/4" steel rod 1/4" acetal rod
6	Hollow Rod / Tube	Hollow Cylinder	<ul style="list-style-type: none"> Copper tubing PVC pipe
7	Angle	90° "L" shape	<ul style="list-style-type: none"> 1" x 1", 1/16" thickness aluminum angle
8	U- / C-Channel	"U" or "C". See this Q&A.	<ul style="list-style-type: none"> 1/4" High x 1" Wide Aluminum U-Channel
9	Non-Metal 3D Printer Filament	Thin cylinder	<ul style="list-style-type: none"> PLA or TPU filament Composite nylon filament (e.g. Markforged Onyx™)
10	Synthetic Polymer used for Molding	Liquid	<ul style="list-style-type: none"> Polyurethane Silicone

Teams are not required to exhaustively define the specific material type for each component of every *Fabricated Part* in their Engineering Notebook, as it should be obvious from the engineering drawings required by <VUR7>. However, unusual parts should be expected to receive increased scrutiny.

If any materials do not easily fall into one of these categories, then that is probably an indication that it is not intended to be a legal type of *Raw Stock*. If a *Team* cannot demonstrate that the component was made from a legal type of *Raw Stock*, then they will be asked to remove it from their *Robot*.

Significant Q&As:

- 1585 - [Producing "Raw Material" via Casting/Molding](#)
- 1814 - [Teams cannot cut non-legal raw stock into legal raw stock](#)

<VUR5> The following material types are **not considered Raw Stock**, and are therefore not permitted:

	Type	Examples
1	Any otherwise-legal <i>Raw Stock</i> that has been post-processed by drilling, machining, or otherwise removing material	<ul style="list-style-type: none"> • Angle aluminum with regularly-spaced holes or slots • Perforated sheet metal
2	Extrusions that do not fall under one of the categories listed in <VUR4>	<ul style="list-style-type: none"> • Non-rectangular aluminum extrusions, such as 80/20, T-slot, or Octanorm • Gear stock
3	Assembled items (or pre-arranged kits of unassembled items) that form a single, more complex component	<ul style="list-style-type: none"> • Gearboxes • Claw mechanisms • Swerve drive modules
4	Commercial off-the-shelf items that are intended to be used with minimal modification	<ul style="list-style-type: none"> • Wheels • Gears • Timing belts and pulleys
5	Materials that are intended to be cast or sintered	<ul style="list-style-type: none"> • Resin / powdered-bed 3D printing • Molten aluminum used for sand casting

Note: <VUR2> takes precedence over this rule. Materials purchased from VEX Robotics that fall under one of these categories (e.g., VersaFrame pre-drilled extrusion) are permitted.

In industry, terms like "raw stock", "raw material", and "material stock" are often used interchangeably, and cover an extremely broad scope of physical goods. The lists in <VUR4> and <VUR5> are intended to explain what specific material types and profiles fall under the defined term "*Raw Stock*" in the context of the VEX U competition.

<VUR6> *Fabricated Parts* may not be made from *Raw Stock* which poses a **safety or damage risk** to the event, other *Teams*, or Field Elements. Examples of prohibited materials include, but are not limited to:

- Any material intended to produce flames or pyrotechnic effects.
- Any material that is liquid at the time of the *Match*. Examples include hydraulic fluids, oils, greases, liquid mercury, and tire sealant.
 - This does not include fabrication processes that involve the use of liquids, such as milling coolant or epoxy.

- c. Any matter that shatters or otherwise presents an excessive field/safety hazard upon failure. Examples include fiberglass, acrylic, and carbon fiber sheet/tube stock.
 - i. This rule refers specifically to material legality itself. Any potentially unsafe mechanisms made from legal *Raw Stock* may still be addressed by <S1> and <R5>.

Significant Q&As

- 1854 - [Teams cannot embed fiberglass into Fabricated Parts](#)

<VUR7> Fabricated Parts must be made by Team members. Any *Fabricated Parts* must be accompanied by documentation that demonstrates the *Team's* design and construction process for that *Fabricated Part*.

- a. The minimum acceptable form of documentation is an engineering drawing with multiple views for the part in question. These drawings may be included in a *Team's* Engineering Notebook or in a standalone appendix to the Engineering Notebook.
- b. Any *Fabricated Part* must have been entirely designed and produced by *Team* members. For example, parts ordered by the *Team* and 3D printed by a third party would be prohibited.
- c. *Teams* will be required to provide this documentation as requested by inspectors, *Head Referees*, or judges at any time at an event. Failure to provide acceptable documentation will result in the part being deemed illegal for use; therefore, <R3>, <R27>, and/or <G1> will apply.

Significant Q&As

- 1627 - [Fabricated Parts must be designed and produced by current-season Team members](#)
- 1734 - [Team members must be directly involved in the production of Fabricated Parts](#)

<VUR8> *Teams* may use **commercially-available springs** on their *Robots*. For the purposes of this rule, a "spring" is any device used for storing and releasing elastic potential energy. Examples include, but are not limited to:

- a. Compression, tension, torsion, constant force, or conical springs made from spring steel.
- b. Springs made from elastic thread or rubber, such as surgical tubing, bungee cords, or stretchable braided rope.
- c. Closed-loop (pneumatic) gas shocks.

Note: Gas shocks are not considered pneumatic devices in the context of <VUR13>. Gas shocks may not be modified in any way.

<VUR9> *Teams* may use **commercially available fastener hardware** on their *Robot*. For the purposes of this rule, a "fastener" is a part designed and used to join or secure together two otherwise legal parts. Legal examples include (but are not limited to):

- Screws, nuts, rivets
- Hinges, pins, rod ends, threaded rods, hose clamps
- Ancillary fastener accessories, such as washers or spacers
- Adhesives such as epoxy, glue, or tape (when used to join together two parts)

If the primary function of the part is not “fastening”, then <VUR5>, <VUR6>, and/or <VUR7> take precedence over this rule. Illegal examples include (but are not limited to):

- A prefabricated non-VEX wheel, even though it may technically connect tread to a shaft
- 80/20 extrusion; other items get “fastened to it”, it is not the part doing the “fastening”
- Using grip tape to improve wheel traction

Note: Prior to version 2.2 of the Game Manual, this rule also included bearings. Bearings are now covered by rule <VUR14>.

Significant Q&As:

- 1927 - [D-rings, when used as Fasteners, are legal under this rule](#)

<VUR10> Each *Robot* must utilize exactly **one (1) V5 Robot Brain and up to two (2) V5 Robot Radios** connected to a V5 Controller.

- Teams* must abide by the power rules noted in <R13> and <VUR12c>.
- Wireless communication between *Robots* is permitted if using legal V5 Robot Brains / Robot Radios. No other types of wireless communication protocols (e.g., radio, Bluetooth, Wi-Fi) are permitted.

<VUR11> There is **no restriction on the number of V5 Smart Motors (11W) [276-4840] and/or EXP Smart Motors (5.5W) [276-4842]** that *Robots* may use. No other motors, servos, or electronic actuators are permitted, including those sold by VEX (e.g., the 2-Wire 393 Motor).

Note 1: Rule <R14> still applies in VEX U. Teams may not modify Smart Motors, and must use official/unmodified gear cartridges

Note 2: Commercially available pneumatic actuators and pneumatic solenoids are permitted within the guidelines of <VUR13>

Note 3: Legal Additional Electronics may include their own motor, servo, or actuator, per <VUR12>

<VUR12> There is **no restriction on sensors and other Additional Electronics** that *Robots* may use for sensing and processing, except as follows:

- Sensors and *Additional Electronics* **MUST** be connected to the V5 Robot Brain via any of the externally accessible ports (i.e., without any modification to the microcontroller). A sensor may be connected to a processing unit which then connects to the V5 Robot Brain.

- b. Sensors and *Additional Electronics* CANNOT directly electrically interface with VEX motors and / or solenoids.
- c. The additional sensors and electronics may only receive power from any of the following:
 - i. Directly from the V5 Robot Brain via any externally accessible port.
 - ii. From an additional lithium ion, lithium iron, or nickel metal hydride battery pack (only one (1) additional battery can be used for sensor/processing power). This additional battery pack must operate at a maximum of 12 volts nominal.
- d. Only the V5 Battery can power the V5 Brain.
- e. *Additional Electronics* which include a low-powered motor as an integral part of their primary sensing/processing function, such as an external processor's cooling fan or a spinning sensor, are permissible.
 - i. Standalone motors which serve no additional sensing or processing functionality (e.g., using a commercially-available brushless motor in a drivetrain) are not considered legal *Additional Electronics*, and would be considered a *Violation* of <VUR11>.
- f. Pneumatic solenoids are the only types of solenoids that are permitted as *Additional Electronics*. Solenoids used for any purpose other than opening and closing a pneumatic valve are considered an actuator and therefore prohibited, per <VUR11>.

<VUR13> *Teams* may utilize an **unlimited amount of the following commercially available pneumatic components**: cylinders, actuators, valves, gauges, storage tanks, regulators, manifolds, tubing, and solenoids.

- a. Pneumatic devices may only be charged to a maximum of 100 psi.
- b. Compressors or any other forms of "on-Robot" charging are not permitted.
- c. All commercial components must be rated for 100 psi or higher. *Teams* should be prepared to provide documentation that verifies these ratings to inspectors if requested.
- d. Components must not be modified from their original state, other than the following exceptions:
 - i. Cutting pneumatic tubing or wiring to length; assembling components using pre-existing threads, brackets, or fittings; or minor cosmetic labels.
- e. If commercially available 12V solenoids are used, these are considered *Additional Electronics* and must therefore satisfy all conditions listed in <VUR12>. 12V solenoids may be either powered by an additional power source (per <VUR12c>), or by a 5V-12V step-up converter from the V5 Robot Brain. If an external power source (or other *Additional Electronics* device) is used to interface with the solenoid, *Teams* MUST be able to demonstrate that there is no way for the solenoid to receive power while the *Robot* is receiving a disabled state from the field controller.

<VUR14> **Teams may use commercially available bearings on their Robot.** For the purpose of this rule, a 'bearing' is a part that supports external loads, reduces friction, and improves efficiency by facilitating smooth dynamic motion between components. Legal examples include (but are not limited to):

- Parts supporting rotational motion: radial bearings, roller bearings, thrust bearings, needle bearings, one-way bearings, bushings, etc.
- Parts supporting linear motion: linear bearings, linear slides, drawer slides, etc.

Team Composition

We want to see Universities face off in a global head-to-head competition. Schools are not limited to one *Team*, and a *Team* may consist of multiple colleges, but we hope that each *Team* identifies with and proudly represents one (1) post-secondary institution. (e.g., "Clarkson University" vs. "UC Santa Barbara"). Of course, college-level "club" *Teams* and mixed composition *Teams* are encouraged to join! However, as noted in <VUT7>, *Students* who have not yet graduated secondary school are not eligible to participate in VEX U, even if they are "dual-enrolled" or taking post-secondary courses.

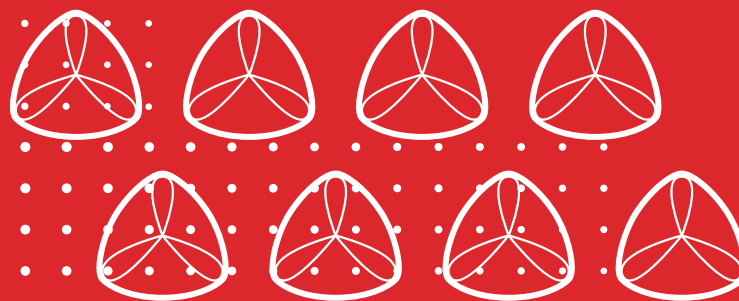

vEX[®]
ROBOTICS
COMPETITION
OVER UNDER

2023 - 2024
Appendix D - VEX AI

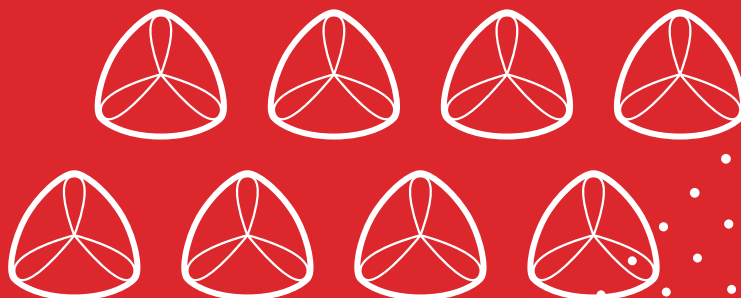

Appendix D - VEX AI

Introduction

Artificial Intelligence (AI) is becoming a staple in today's industry. The VEX AI Robotics Competition (VAIRC) gives teams of *Students* a chance to compete in this growing field. With just a few additional sensors, *Teams* will be playing in one-vs-one *Matches* using two *Robots* per *Team* (i.e. four *Robots* on the field) that are fully autonomous. *Robots* will be functioning without input from drivers and instead are communicating with each other as the *Match* progresses through two minutes. VAIRC is the perfect project-based supplement to many High School and University-level engineering programs and will give *Students* the unique opportunity to demonstrate their real-world AI skills to potential employers (such as REC Foundation sponsors).

The 2023-2024 season will provide more opportunities than ever before for VAIRC competitors, such as VAIRC divisions at select VEX U events, and the opportunity to submit Robot Skills Challenge scores at any local VRC event (via the same process currently used by VEX U *Teams*).

Game, Robot, and Tournament Rules

Please consult the VEX Robotics Competition Over Under Game Manual for the basic set of competition rules and details. Most VAIRC rules are based on the VEX U rules, which can be found in Appendix C. As such, all standard VEX U Game, Robot, & Tournament rules apply, except for the modifications listed in this document. In the event of a rules conflict, the rules listed in this document and rulings on the VEX U Q&A take precedence.

Rule Modifications: Field Setup

The VEX AI Robotics Competition uses a standard VRC Over Under field, set up the same as a VEX U *Match*, as shown below and in Appendix C.

A VEX GPS Code Strip and opaque field panels are **required** for VAIRC matches. Although the VRC Portable Field Perimeter is preferred, as it already meets these criteria, a metal field perimeter may be used if modified accordingly.

Game Definitions

Base Team - A VRC or VEX U *Team* whose members also compete in VAIRC on a *Crossover Team*.

Crossover Team - A VAIRC *Team* whose members also compete on a VRC or VEX U *Base Team*. See rules <VAIR3> and <VAIT3>.

Double-Cornered - A *Team* status. A *Team* meets the definition of being “*Double-Cornered*” if both *Robots* are in the same “corner” of the field.

- Being “in” the corner means that the *Robots* are contacting the gray tiles within a given corner, and not contacting any other tiles.
- A “corner” is defined as one of the four sets of nine gray foam field tiles that are bordered by the field perimeter, the double set of white tape lines, and the Long *Barrier*.
- The white tape lines are considered “neutral”. For example, if a *Robot* is in Corner 2, it is not considered to be in Corner 1 until it contacts the Corner 1 foam tile past the second white tape line.
- Contact with other Field Elements (such as *Match Load Bars* or the *Barrier*) is irrelevant.

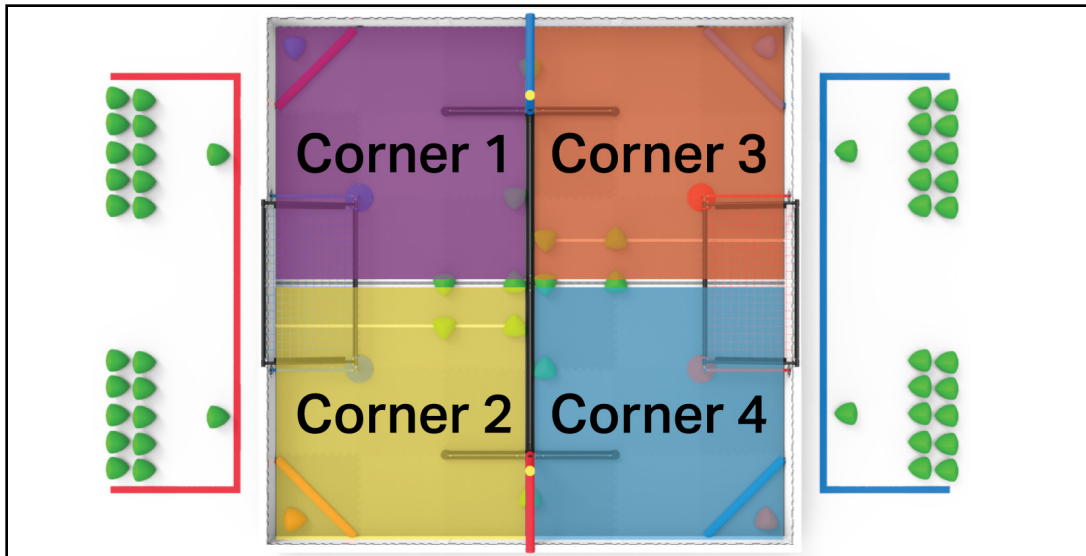

Interaction Period - The 75-second (1:15) time period that follows the *Isolation Period* after the winner of the *Isolation Period* has been determined. *Robots* react only to sensor inputs and to commands pre-programmed by the *Students* into the *Robot* control system and can interact with the entire field during the *Interaction Period*. The *Interaction Period* replaces the *Driver Controlled Period* normally found in a VEX U Match.

Isolation Bonus – A point bonus of eight (8) points awarded to the *Team* that has earned the most points at the end of the *Isolation Period*. The *Isolation Bonus* replaces the *Autonomous Bonus*.

Isolation Win Point – One (1) *Win Point* (WP) given to an *Alliance* that has completed the *Autonomous Win Point* criteria set forth in rule <VUG6>. The *Isolation Win Point* replaces the *Autonomous Win Point*.

Isolation Period - A 45-second (0:45) time period during which *Robots* operate only on their side of the field and react only to sensor inputs and to commands pre-programmed by the *Students* into the *Robot* control system. This *Isolation Period* replaces the *Autonomous Period* normally found in a VEX U Match.

Rule Modifications: Game

<VAIG1> All <VUGx>, <SCx>, and <Sx> rules apply as written. All <Gx> and <SGx> rules apply as written, except for those modified below or by <VUGx> rules.

Note: All references assume that the terms "Autonomous Period" and "Driver Controlled Period" are replaced with "Isolation Period" and "Interaction Period", respectively.

<VAIG2> As noted by <G11>, *Drive Team Members* are not permitted to interact with their *Robots* in any way while they are operating autonomously (i.e., during the entirety of a *VAIRC Match*). The following exceptions are permitted:

- a. Using sensors to detect legally-entered Match Load *Triballs*.
- b. Using a V5 Controller to disable a *Robot* which is engaging in reckless or unsafe behavior. *Robots* which are disabled may not be re-enabled for the rest of the *Match*.

<VAIG3> Just as VRC and VEX U *Teams* are responsible for the actions of their *Robots* during the *Autonomous Period*, *VAIRC Teams* are responsible for the actions of their *Robots* throughout the entirety of a *VAIRC Match*. Excessive or egregious *Violations* of the following rules may result in a *Major Violation / Disqualification*, as well as the *Head Referee* directing a *Team* to disable their *Robot*:

- a. <G13> ("Don't destroy other *Robots*.")
- b. <G16> ("No *Holding* for more than a 5-count.")
- c. <VAIG4> ("Stay out of your opponent's *Goal* unless they are *Double-Cornered*.")
- d. <SG9> ("Stay in your starting *Zone* during *Autonomous*.")

In the context of this rule, "excessive or egregious" refers to a *Violation* or interaction that the *Head Referee* has judged to be out of the *Robot's* control and/or is not showing any signs of improvement. Examples may include, but are not limited to:

- Holding an opponent for 15+ seconds
- Repeated *Violations* of <VAIG4> in the same *Match*
- Repeated *Violations* of <SG9> across multiple *Matches*

<VAIG4> This rule supersedes <SG8>. *Robots* are only permitted to “break the plane” of an opponent’s *Goal* if they are *Double-Cornered*.

- a. This allowance ends once the *Alliance* is no longer *Double-Cornered*.
- b. Entering an opponent’s *Goal* at any other time is prohibited. This includes staying inside of an opponent’s *Goal* after ending a *Double-Cornered* status, or contacting foam tiles under a *Goal* that are in an adjacent corner.
- c. This rule applies to both intentional and unintentional interactions. *Teams* are responsible for the actions of their own *Robots*.
- d. This rule only applies during the *Interaction Period*. Entering an opponent’s *Goal* is not permitted at any time during the *Isolation Period*.
- e. If a *Team* has only one *Robot* present, then that *Team* can never meet the definition of *Double-Cornered*, and therefore its *Goal* is never open for opponent interactions.

Rule Modifications: Tournament

<VAIT1> The following VEX U rules apply as written:

- <VUT1> (*Matches* are played 1-*Team* vs 1-*Team*, with two *Robots* each)
- <VUT2> (*Qualification Matches* are a 1v1 version of a standard VRC tournament)
- <VUT3> (*Elimination Matches* are a 1v1 version of a standard VRC tournament)
- <VUT6> (Each *Robot* is permitted up to three *Drive Team Members*)

The following VEX U rules apply, replacing the terms “*Autonomous Period*” and “*Driver Controlled Period*” with “*Isolation Period*” and “*Interaction Period*”, respectively:

- <VUT4> (The *Autonomous Period* / *Isolation Period* is 45 seconds)
- <VUT5> (The *Driver Controlled Period* / *Interaction Period* is 75 seconds)

<VAIT2> VEX AI Robotics Competition *Teams* may consist of *Students* that fall into one of the following categories:

- a. *High School Students*, as described by the definition of *Student*. This includes *Middle School Students* who are “playing up” and competing as *High School Students*
- b. *University Students*, as defined by rule <VUT7>

Note: The same Team may not consist of Students that fall into both categories (i.e. a blended High School and University Team).

<VAIT3> *Students may only participate on one (1) VAIRC Team in a given season. However, Students on Crossover Teams are still permitted to participate on their Base Team.*

It is expected that VAIRC Teams will be formed by existing VRC and VEX U organizations. The term “Crossover Team” is intended to clarify that Students will not have to “choose” between VRC and VAIRC, e.g., in the context of <G4> or <VUT7>.

However, if a Crossover Team and the associated Base Team both attend an event which has concurrently scheduled Matches between the two programs, Students (especially Drive Team Members) should be expected to choose which Team they are competing with for the duration of that event. “Our driver is in a VAIRC match” would not be considered an acceptable justification for being late to a VRC Match (or vice-versa).

Note: See <VAIR3> for more details regarding how this rule pertains to Robots.

Rule Modifications: Robot

<VAIR1> All <VURx> rules apply as written. All <Rx> rules apply as written, except for those modified below or by <VURx> rules.

<VAIR2> Any components used for AI vision processing, such as those found in the VEX AI kit (276-8983), are considered standard *Additional Electronics* and must abide by <VUR12> as-written.

<VAIR3> Although VAIRC Crossover Teams are encouraged to build separate Robots from their Base Team counterparts, it is not required. The Robot(s) built by a Base Team may be used by their associated Crossover Team for VAIRC Matches. Therefore, <R1> does not “cross programs” between VAIRC Teams and their associated VRC Base Team.

Note: This allowance is “one-way” for VAIRC Matches. Participation in VAIRC does not create any <R1> exemption for VRC Matches and events. For example, <R1c> still applies; a VRC Base Team may not switch between their Crossover Team’s other VAIRC Robot(s) for different VRC Matches.

If a Crossover Team and the associated Base Team attend an event which has concurrently scheduled Matches between the two programs, Teams would be advised to have separate Robots for each Team. Event Partners will not be expected to adjust Match schedules around Team conflicts between the two programs; “our Robot is in a VAIRC Match” would not be considered an acceptable justification for being late to a VRC Match (or vice-versa).